



Founded in 1946

Project: _____

Items: _____

Quantity: _____

Approval: _____

Date: _____

Utility Stock Cart Model SC1652T

- Ideal cart for universal applications in all departments. Excellent transporter for stockroom, shipping and selling floor.
- 16" width deck is ideal for narrow aisles.
- All welded, tubular steel construction with aluminum powder coated finish.
- Gusseted uprights for added strength.
- Maneuvers easily on two 6" stationary center load wheels and four 4" polyurethane swivel end casters. Six wheel design allows cart to swivel within its own radius.

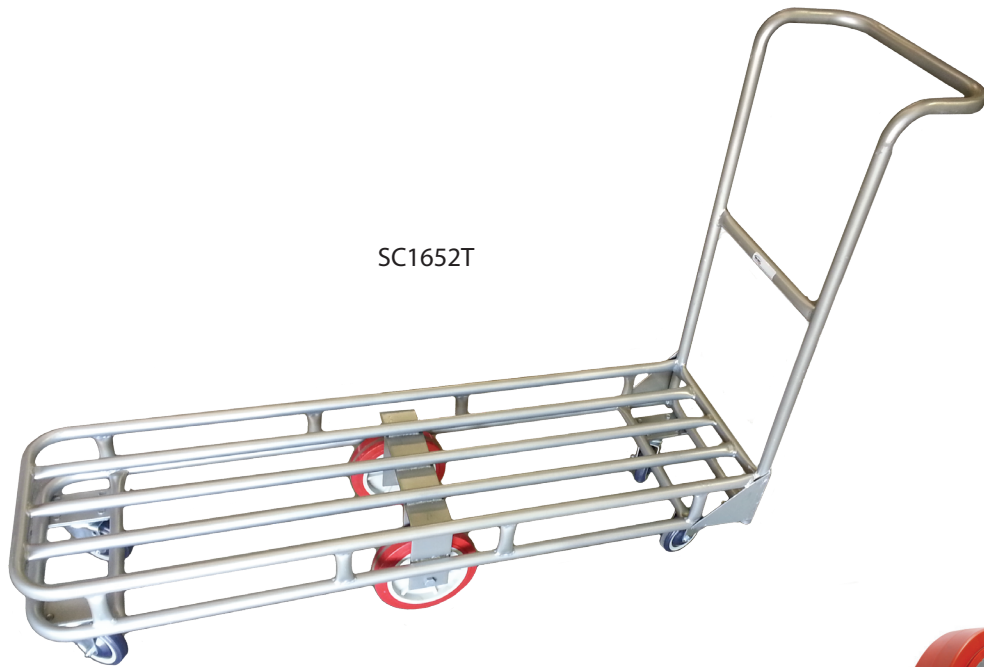

SC1652T

Polyurethane Wheels for Heavy Duty Applications, Long Life, Low Maintenance, Non-Marking.





Founded in 1946

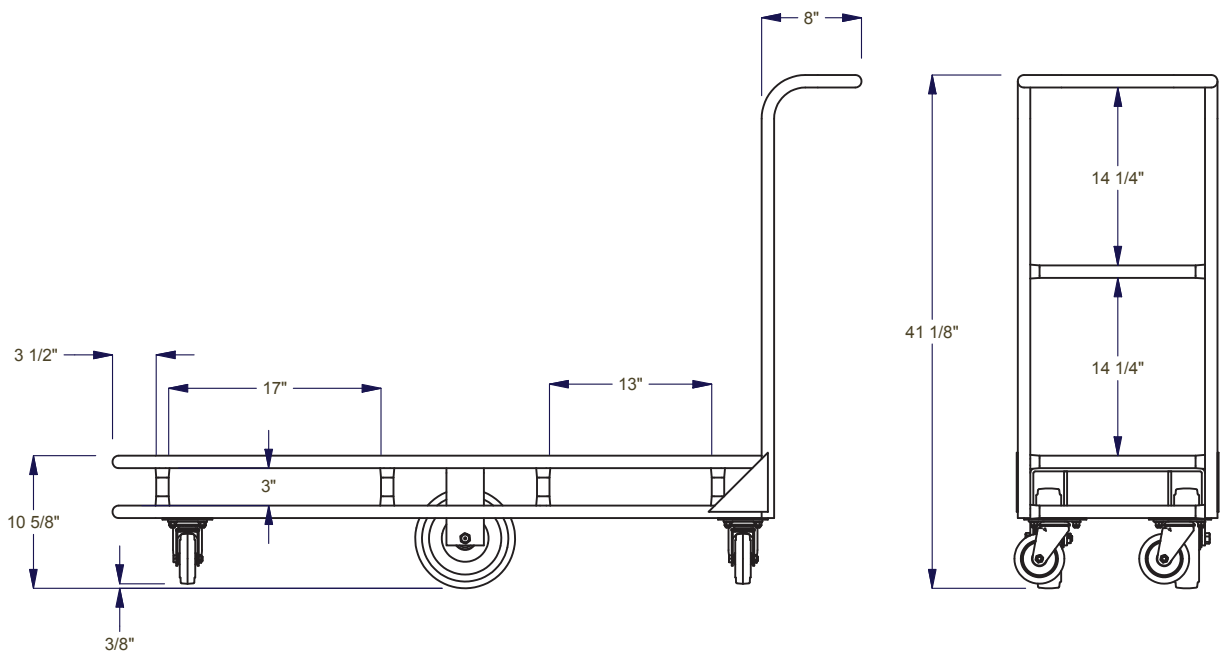
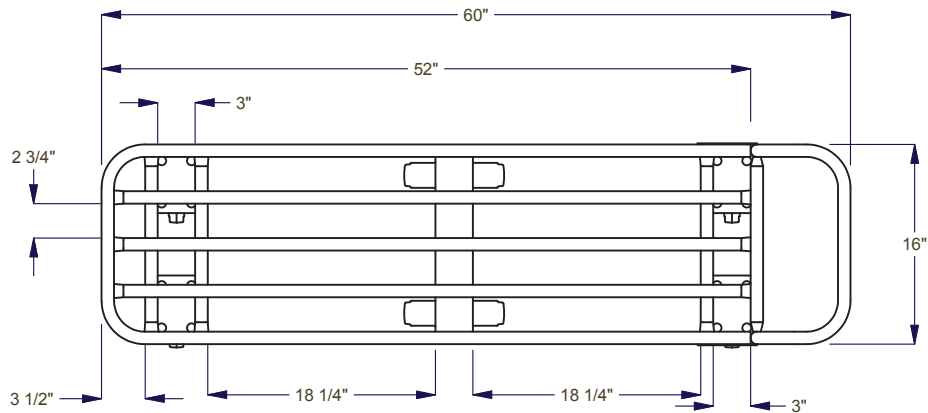

Model Number	Order#	Overall Dimensions						Capacity		Approx. Ship Wt	
		Width		Length		Height		(lb)	(kg)	(lb)	(kg)
		(in)	(mm)	(in)	(mm)	(in)	(mm)				
SC1652T	232223	16	508	42	1067	36	914	1,200	544	36	16

Caster Information
 8" Polyurethane Center Wheel 7130 (122462)
 Swivel Plate Caster with 4" Rubber Wheel 732 (123078)
 4" Rubber Wheel 716 (122673)
 Freight Class: 70

In line with our policy to continually improve our products, Winholt reserves the right to change materials and specifications without notice. 6.2014