

# READY-BILT™

FACTORY PRE-ASSEMBLED WALK-INS



FROM

**MB** MASTER-BILT®  
*Refrigeration Solutions*

**R**eady-Bilt walk-ins are completely pre-assembled at the factory and ready to set in place at the job site. Structures arrive at the site typically on a gooseneck truck and, depending on size and customer preference, lifted into place by crane, boom-lift or forklift. No field installation is necessary. The refrigeration system(s) is already installed and the entire walk-in is fully tested before shipping. All you have to do is provide electricity for the single source hook-up (one per refrigeration system). Each Ready-Bilt walk-in is UL-listed as an entire package, not just for individual components, facilitating electrical inspections.

# MB MASTER-BILT® READY-BILT™

## STANDARD FEATURES:

- Single or double compartment models available
- Available in a variety of lengths and widths
- Four-inch thick foamed-in-place polyurethane panels with cam-locking mechanisms
- Interior and exterior panel finish of 26 gauge acrylic-coated stucco galvanized
- Choice of 26" x 78", 30" x 78" or 36" x 78" door sizes
- Heavy-duty door closure
- Dial thermometer
- Door drip guard
- NSF-listed .080 textured finish aluminum floor for added slip-and-fall protection.
- Bands of aluminum treadplate for finishing trim around top and bottom of walk-in
- Weather-proof membrane roof to keep rain from collecting against the adjacent building
- Pre-installed refrigeration system(s) using either a remote M-Series condensing unit or a PRS-2 series packaged system depending on application
- Durable hard copper soldered piping on M-Series refrigeration systems
- Vapor-proof light
- Weather-proof light switch cover
- A warranty that covers parts and labor for one year, the compressor for one year (optional extended four year warranty available) and walk-in panels for 15 years

## OPTIONS INCLUDE:

- Door kickplates
- Interior and exterior ramps
- Interior and exterior finish options include all those found in our custom walk-ins
- LED or fluorescent lighting
- MBWA-1 digital alarm and light management system
- Patented\* Master Controller Reverse Cycle Defrost system for M-Series refrigeration systems controls an electric expansion valve and replaces many mechanical components with ultra-efficient solid state technology. Reverse cycle defrost saves up to 80% in defrost energy usage over electric heaters while providing a completely "clean" defrost in as little as 3-5 minutes in a freezer or 1½– 2 minutes in a cooler. The integrated Web2Walk-In application gives users constant access to refrigeration system performance data. The internet-based program can be accessed almost anywhere by computer or Android™-based smartphone.

\*U.S. patent no. 7,073,344



908 Highway 15 North • New Albany, MS 38652  
800-647-1284 • FAX: 800-232-3966  
www.master-bilt.com

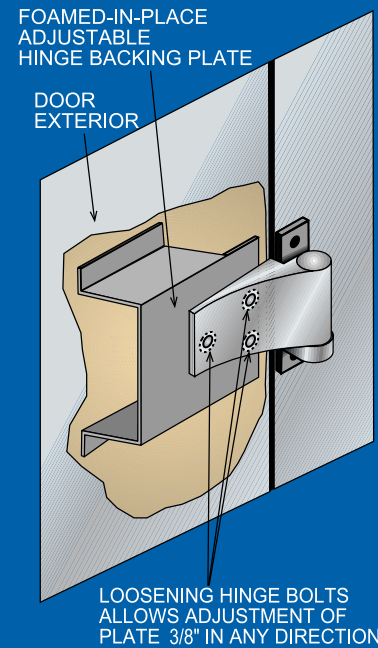

**Unique adjustable hinge backing plates in every entry door ensure a proper fit during installation and allow for any necessary future adjustments without removal of the door or its frame.**



**Ready-Bilt walk-ins are equipped with heavy-duty doors containing:**

- A heavy-gauge, Z-shaped structural inner frame (shown above) with a full length 1/4" inch thick steel tapping plate
- Inner heater wires lining the perimeter (two wires provided for freezer doors)