

# D

## FULLY JACKETED DIRECT STEAM STATIONARY PEDESTAL BASE KETTLE

JOB NAME: \_\_\_\_\_

ITEM NO.: \_\_\_\_\_

NO. REQUIRED: \_\_\_\_\_

**FOOD SERVICE EQUIPMENT**  
Fully Jacketed Direct Steam Kettle

### MODELS

- F-20PF** - 20 gallon (76 liter), direct steam, fully jacketed, stationary pedestal base kettle
- F-30PF** - 30 gallon (114 liter), direct steam, fully jacketed, stationary pedestal base kettle
- F-40PF** - 40 gallon (152 liter), direct steam, fully jacketed, stationary pedestal base kettle
- F-60PF** - 60 gallon (227 liter), direct steam, fully jacketed, stationary pedestal base kettle
- F-80PF** - 80 gallon (303 liter), direct steam, fully jacketed, stationary pedestal base kettle

### DESCRIPTION

Will be a Market Forge direct steam connected, stationary pedestal, steam jacketed.

Kettle will be constructed of welded satin finish stainless steel, type 304. A double wall kettle interior will form a full jacket around the lower of the kettle. The kettle bottom will be of elliptical design for superior heat circulation.

The pedestal base shall have four 7/16" (11mm) holes evenly spaced for securing unit to the floor.

Unit will include as standard a steam control kit (STA-1), and a Steam trap that includes a steam control valve (steam inlet globe valve), line strainer, and spring assist stainless steel cover.

### OPERATION WILL BE BY

Direct steam at 5-35 PSI (0.3-2.5 kg/cm<sup>2</sup>). An optional pressure reducing valve is required if incoming pressure exceeds kettle rating.

### STEAM FLOW REQUIREMENTS

34 lbs. (15.5 kg) steam per hour or 1 BHP per 20 gallons (76 liters) of kettle capacity.

MODEL	BHP/Hour	Lbs. Steam/Hour
F-20PF	1.0	34.5
F-30PF	1.5	52.0
F-40PF	2.0	69.0
F-60PF	3.0	103.5
F-80PF	4.0	136.0



F-40PF shown

### SHIPPING WEIGHT

- F-20PF** - 225 lbs (102 kg)
- F-30PF** - 245 lbs (111 kg)
- F-40PF** - 270 lbs (122 kg)
- F-60PF** - 295 lbs (134 kg)
- F-80PF** - 320 lbs (145 kg)

### OPTIONS & ACCESSORIES

(at additional charge)

#### ■ Pantry Faucets

- Double pantry faucet with swing spout and mounting bracket
- Single pantry faucet with swing spout and mounting bracket
- Triple basket assembly
- 3" draw-off valve with strainer
- Strainer hook
- Etched Gallon Markings
- Wall models (consult factory)
- Graduated measuring stick
- BFT - ball float trap
- PRV - pressure reducing valve
- Type 316 stainless steel liner for high acid content products
- H.P. 50 PSI (3.5 kg/cm<sup>2</sup>) rated
- Prison package, s/s plate over tangent draw-off valve, tamper proof screws, chrome plated steam control, lockable s/s spring assist hinged cover, reinforcement bar



**MARKET FORGE**  
INDUSTRIES INC.

# D

## FULLY JACKETED DIRECT STEAM STATIONARY PEDESTAL BASE KETTLE

DETAILS & DIMENSIONS

### DIMENSIONS

MODEL	A	B	C	D	E	F	G	H	J	K	L	M
F-20PF	26 [660]	15.75 [400]	37 [940]	27.5 [699]	19 [483]	14.25 [362]	16 [406]	16.88 [429]	30.63 [778]	18.75 [476]	64.5 [1638]	65 [1651]
F-30PF	29.5 [749]	17.5 [445]	37 [940]	31 [787]	17.25 [438]	16 [406]	17.75 [451]	16.88 [429]	29.69 [754]	17 [432]	68 [1727]	68 [1727]
F-40PF	33 [838]	19.25 [489]	37 [940]	34.5 [876]	15.5 [394]	18 [457]	19.5 [495]	19.63 [498]	29.13 [740]	15.25 [387]	71.5 [1816]	71.5 [1816]
F-60PF	35.5 [902]	20.5 [521]	40.5 [1029]	37 [940]	17.75 [451]	17.5 [445]	20.75 [527]	19.63 [498]	32.13 [816]	17.5 [445]	77.5 [1969]	77.5 [1969]
F-80PF	42 [1067]	23.75 [603]	40.5 [1029]	43.5 [1105]	14.5 [368]	18.75 [476]	24 [610]	19.63 [498]	15.88 [403]	14.25 [362]	84 [2134]	83 [2108]

### SERVICE CONNECTIONS

<b>S</b>	<b>Steam Supply</b> - 3/4" IPS (19mm) at 5-35PSI (0.3-2.5 kg/cm <sup>2</sup> ), Optional 5-50PSI (0.3-3.5 kg/cm <sup>2</sup> )
<b>CR</b>	<b>Condensate Return</b> - 1/2" IPS (13mm)
<b>CW/HW</b>	<b>Cold and Hot Water</b> - 3/8" (10mm) O.D. tubing for cold and hot water to optional kettle fill faucet

FOOD SERVICE EQUIPMENT  
Fully Jacketed Direct Steam Kettle

DIMENSIONS ARE IN INCHES [MM]

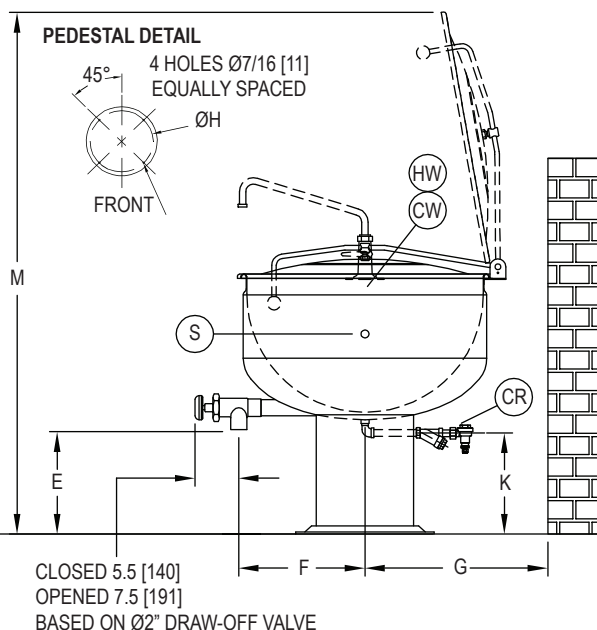
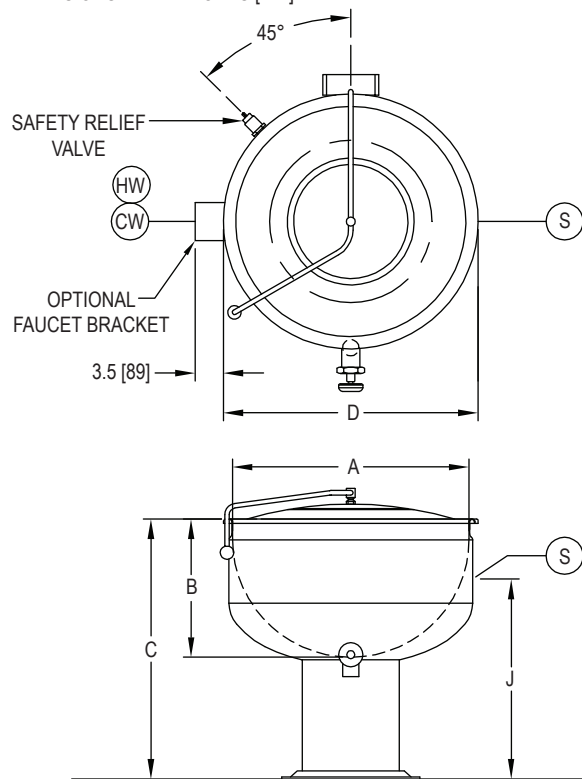

The manufacturer reserves the right to modify materials and specifications without notice.

PRINTED IN U. S. A.  
SPEC SHEET: 14-0136 Rev B (10/15)



44 Lakeside Avenue, Burlington, VT 05401 USA • Tel: (802) 658-6600 • Fax: (802) 864-0183  
www.mfii.com