

HOBART701 S Ridge Avenue, Troy, OH 45374
1-888-4HOBART • www.hobartcorp.com**FT1000S ENERGY RECOVERY
FLIGHT-TYPE DISHWASHER****HOBART****FT1000S ENERGY RECOVERY FLIGHT-TYPE DISHWASHER****STANDARD FEATURES**

- Pumped rinse system (pressure gauge not required)
- Water usage 58 gph
- Digital controls with machine diagnostics
- Low temperature alert
- Single point vent location
- 31" access on prewash and power wash chambers; 20" access on dual rinse and ASR chambers
- Start and stop switches at both ends
- Doors open indicator
- Drains open indicator
- Door interlocks
- 3½ H.P. prewash, and 5 H.P. power wash pump motors, all TEFC
- Capless Auto Clean wash arms
- Easy to remove stainless steel scrap pans and baskets
- 30" wide conveyor belt
- Dual Rinse
- Automatic Soil Removal system (ASR)
- Auto Clean
- Auto Delime
- Energy Recovery
- Front and rear panels
- Variable speed conveyor

DIRECTION OF OPERATION

- Right to Left
- Left to Right

VOLTAGE

- 208/60/3
- 240/60/3
- 480/60/3
- Other voltages available – consult factory

MODEL

- FT1000S Energy Recovery Flight-Type Dishwasher

OPTIONS AT EXTRA COST

- Electric Tank Heat
- Steam Tank Heat
- Booster Heater
 - Electric
 - Steam
- 6" higher than standard chamber
- Multiple conveyor choices
- Circuit breakers
- Security package
- Other options available, consult factory

ACCESSORIES

- Flanged feet
- Water hammer arrestor/PRV (installed by others)
- Drain water tempering kit (installed by others)
- Vent connection kit

Specifications, Details and Dimensions on Inside and Back.



- LA Research Report M660004
- Complies with EPA Reduction of Lead in Drinking Water Act 2014
- Meets requirements of ASSE Standard No. 1004

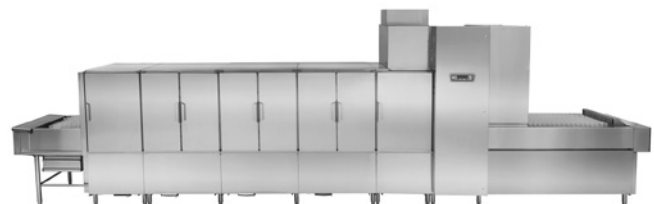

FT1000S ENERGY RECOVERY FLIGHT-TYPE DISHWASHER



701 S Ridge Avenue, Troy, OH 45374
1-888-4HOBART • www.hobartcorp.com

DESIGN: Fully automatic, flight-type dish machine consisting of a load section with Automatic Soil Removal system, power recirculating prewash, power wash and dual rinse/final rinse section. Included with each machine will be flexible plastic strip curtains to control overspray.

CONSTRUCTION: Stainless steel tank and chambers with No. 3 polish on appearance surfaces. Frame, legs and feet to be constructed of stainless steel. Inspection doors to be chamber width.

PUMPS: Recirculating stainless steel pumps with stainless steel impellers. Pump housing has easy to remove coverplate for access to impeller. Wash pumps are self-draining.

MOTORS: Totally enclosed fan cooled (TEFC) design with overload protection. Pump motors to be 3½ H.P. for prewash, 5 H.P. for power wash, and conveyor motor to be ⅓ H.P. Available in electrical specifications of 208/60/3, 240/60/3 and 480/60/3.

CONTROLS: A stainless steel control center with electronic digital controls mounted at eye level. Power “On/Off” and “Start/Stop” switches integrated into keypad. Digital display indicates door(s) open, low temperature alert, tanks/final rinse temperatures, Auto Clean and Auto Delime instructions and notifications, and other pertinent operating data. Additional “Start/Stop” switches are located at each end of machine. Conveyor speed button to be included on the control center to provide for the adjustable speed conveyor.

FLIGHT-TYPE CONVEYOR: Stainless steel side links, tie rods and conveyor tracks. Injection molded, resilient Duraflex flight links.

VENT: Indirect vent connection with integral powered fan.

AUTOMATIC SOIL REMOVAL SYSTEM (ASR):

Two foot section with specialized soil removal wash arms which removes food soil from the ware before it reaches the prewash tank. System will pump food soil from the ASR tank into an external collector located under the load section, minimizing the need to pre-scrap dishes and reducing detergent consumption. Operator can easily remove and clean external collector without interruption of machine operation.

RECIRCULATING PREWASH SECTION: Prewash compartment is fitted with upper and lower wash arms. Large removable one piece perforated stainless steel screen sloped downward to deep stainless steel scrap basket.

TANK HEAT: Power wash and dual rinse tank water temperatures are thermostatically controlled. Low water protection is provided. Specify either electric or steam heat.

FINAL RINSE: Easily removed final rinse arms.

ENERGY RECOVERY: Energy Recovery system operates with a cold water line, capturing energy from exhaust air, and using it to elevate the temperature of the water entering the booster heater. The result is savings – both in hot water and in energy.

CONVEYOR DRIVE UNIT: Powered by a ⅓ H.P. motor. Trip mechanism provided on unload section. Jam protection is provided by load sensing switch at drive platform. Conveyor speed adjustment of 4 feet per minute to 6.3 feet per minute is provided on the digital display keypad.

DRAINS: Manual, hand-operated, located at each tank. One manual and automatic master drain to be used for Auto Clean and Auto Delime.



701 S Ridge Avenue, Troy, OH 45374
1-888-4HOBART • www.hobartcorp.com

FT1000S ENERGY RECOVERY FLIGHT-TYPE DISHWASHER

No other control system allows easier monitoring.

The digital controls are placed in a convenient panel that lets operators verify proper operation and temperatures at a glance. Digital display indicates the unit is on, and confirms that the doors are closed. Automatic door interlocks prevent the pump and conveyor from operating if the doors are open. Easy-to-read digital display indicates accurate temperatures of the 160°F wash, 160°F dual rinse and 180°F final rinse — critical for proper HACCP system record-keeping.



Stainless steel pump is built for long life.

The stainless steel pump housing and impeller offer greater durability and long life. The pump motor is totally enclosed and fan cooled (TEFC) to protect it from water spray during dishroom clean-up.

Scrap baskets capture food particles and are easy to clean.

The sloped screens that carry scraps to the scrap baskets are steeper, so less soil gets into the tanks. The basket opening is larger for easy cleaning and basket handles have been designed for easy lift-out access. The load section also features a removable scrap basket which contains soil that is pumped from the ASR section. All scrap baskets and strainers are stainless steel for strength and durability.

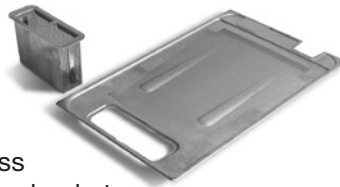

The FT1000 Series saves water and energy.

The unit has the lowest water and energy consumption in the industry, yet

provides effective cleaning and sanitizing that meets NSF International requirements.

This is achieved through a carefully balanced ratio of water flow to pressure. Insulated doors and thermal layered curtains also reduce heat loss. The unit's 58 gallons per hour rinse flow rate saves both water and the energy to heat it.



Variable speed conveyor offers increased throughput.

The conveyor on the FT1000 Series is wider so it can handle more ware.



Result: more volume and versatility, quicker work. Its speed is service adjustable for the type of ware, soiled condition, or workforce requirements. It runs at 4 - 6.3 feet per minute.

Energy Recovery system reclaims heat for energy.

The Energy Recovery system's heat exchanger captures escaping heat and steam from the exhaust air in the dish machine, and uses it to preheat the incoming cold water supply to 120°F before it enters the booster heater. In addition to energy savings, the Energy Recovery system provides a viable use for this otherwise exhausted heat.



Self-draining wash pumps help keep water clean.

Pumps are self-draining when the machine is shut down, so there is no residual water left in the pumps.

Installation is quick and easy with modular design, minimal wiring connections, and single point vent.

Modular design means the FT1000 installs quickly and reliably. The control panel is already in place, premounted to the dual rinse/final rinse section.

Wiring connections are minimal, and there is only a single vent, saving time and expense. The control box uses a "single plane" circuitry design for easy accessibility during installation and service. The FT1000 is ready to run quickly.



FT1000S ENERGY RECOVERY ELECTRIC L-R



701 S Ridge Avenue, Troy, OH 45374
1-888-4HOBART • www.hobartcorp.com

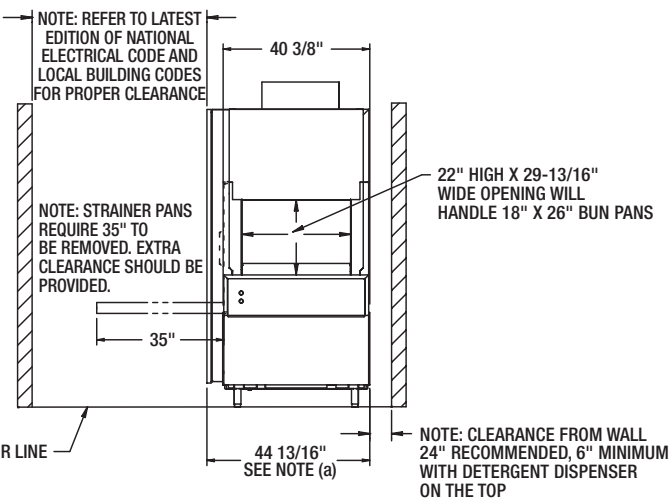
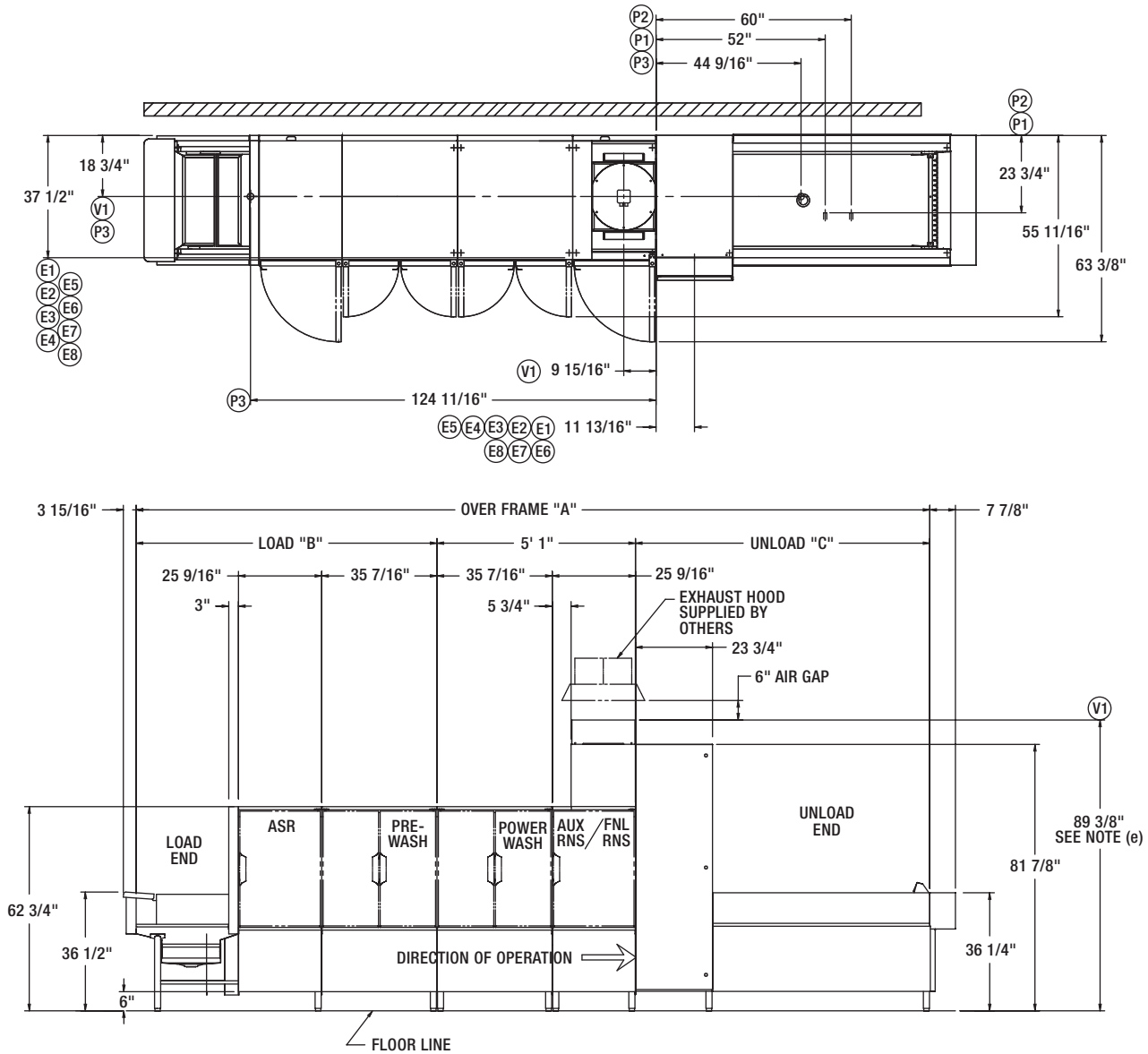

MODEL NO.	"A"	"B"	"C"
FT1018S (7.5'-5"-5.5')	18' 4-9/16"	7' 8-1/2"	5' 7"
FT1019S (8.5'-5"-5.5')	19' 4-5/16"	8' 8-1/4"	5' 7"
FT1020S (9.5'-5"-5.5')	20' 4-5/32"	9' 8-3/32"	5' 7"
FT1020S (7.5'-5"-7.5')	20' 4-1/16"	7' 8-1/2"	7' 6-1/2"
FT1021S (8.5'-5"-7.5')	21' 3-13/16"	8' 8-1/4"	7' 6-1/2"
FT1022S (9.5'-5"-7.5')	22' 3-21/32"	9' 8-3/32"	7' 6-1/2"
FT1022S (7.5'-5"-9')	21' 11-13/16"	7' 8-1/2"	9' 2-1/4"
FT1023S (8.5'-5"-9')	22' 11-9/16"	8' 8-1/4"	9' 2-1/4"
FT1024S (9.5'-5"-9')	23' 11-13/32"	9' 8-3/32"	9' 2-1/4"
FT1024S (7.5'-5"-11')	23' 11-7/16"	7' 8-1/2"	11' 1-7/8"
FT1025S (8.5'-5"-11')	24' 11-3/16"	8' 8-1/4"	11' 1-7/8"
FT1026S (9.5'-5"-11')	25' 11-1/32"	9' 8-3/32"	11' 1-7/8"
FT1027S (7.5'-5"-15')	27' 6-3/4"	7' 8-1/2"	14' 9-3/16"
FT1028S (8.5'-5"-15')	28' 6-1/2"	8' 8-1/4"	14' 9-3/16"
FT1029S (9.5'-5"-15')	29' 6-11/32"	9' 8-3/32"	14' 9-3/16"
FT1029S (7.5'-5"-17')	29' 6-5/16"	7' 8-1/2"	16' 8-3/4"
FT1030S (8.5'-5"-17')	30' 6-1/16"	8' 8-1/4"	16' 8-3/4"
FT1031S (9.5'-5"-17')	31' 5-29/32"	9' 8-3/32"	16' 8-3/4"

NOTE: OVERALL LENGTH OF MACHINE IS DIMENSION "A" + 11 13/16"



701 S Ridge Avenue, Troy, OH 45374
1-888-4HOBART • www.hobartcorp.com

FT1000S ENERGY RECOVERY ELECTRIC L-R

SERVICE CONNECTION WITH CIRCUIT BREAKERS (2) SERVICE CONNECTIONS AS SHOWN BELOW MOTORS, CONTROLS & BOOSTER HEAT (TB1) (1) SERVICE CONNECTION AS SHOWN BELOW			
ELEC. SPECS.	RATED AMPS	MINIMUM SUPPLY CONDUCTOR AMPACITY	MAXIMUM PROTECTIVE DEVICES
208/60/3	87.7	125	125
240/60/3	85.2	125	125
480/60/3	47.9	60	60

WASH, DUAL RINSE HEAT (TB2) (1) SERVICE CONNECTION AS SHOWN BELOW			
ELEC. SPECS.	RATED AMPS	MINIMUM SUPPLY CONDUCTOR AMPACITY	MAXIMUM PROTECTIVE DEVICES
208/60/3	129.0	175	175
240/60/3	123.2	150	150
480/60/3	61.5	80	80

SERVICE CONNECTION W/O CIRCUIT BREAKERS (4) SERVICE CONNECTIONS AS SHOWN BELOW ELECTRIC TANK HEAT, DUAL RINSE (1) 7 KW CONNECTION AS SHOWN BELOW			
ELEC. SPECS.	RATED AMPS	MINIMUM SUPPLY CONDUCTOR AMPACITY	MAXIMUM PROTECTIVE DEVICES
208/60/3	21.0	25	25
240/60/3	20.0	25	25
480/60/3	10.0	15	15

ELECTRIC TANK HEAT, WASH (1) 36 KW CONNECTION AS SHOWN BELOW			
ELEC. SPECS.	RATED AMPS	MINIMUM SUPPLY CONDUCTOR AMPACITY	MAXIMUM PROTECTIVE DEVICES
208/60/3	108.0	125	125
240/60/3	103.2	125	125
480/60/3	51.5	70	70

ELECTRIC BOOSTER (1) 18 KW CONNECTION AS SHOWN BELOW			
ELEC. SPECS.	RATED AMPS	MINIMUM SUPPLY CONDUCTOR AMPACITY	MAXIMUM PROTECTIVE DEVICES
208/60/3	54.0	70	70
240/60/3	51.5	70	70
480/60/3	25.8	35	35

MOTORS AND CONTROLS (1) SERVICE CONNECTION AS SHOWN BELOW			
ELEC. SPECS.	RATED AMPS	MINIMUM SUPPLY CONDUCTOR AMPACITY	MAXIMUM PROTECTIVE DEVICES
208-240/60/3	33.7	45	45
480/60/3	22.1	30	30

⚠ WARNING

Electrical and grounding connections must comply with the applicable portions of the National Electrical Code and/or other local electrical codes.

Plumbing connections must comply with applicable sanitary, safety and plumbing codes. Drain and fill line configurations vary, some methods are shown on this drawing.

NOTICE

Pressure gauge not required on pumped rinse machines.

GENERAL NOTES:

- (a) THE CONTROL BOX IS ATTACHED TO THE CENTER SECTION AND IS ROTATED 90 DEGREES FOR SHIPPING.
AFF = ABOVE FINISHED FLOOR
ALL DIMENSIONS TAKEN FROM THE FLOOR LINE MAY INCREASE 3-1/4" WITH LEG ADJUSTMENT.
FOR CONVENIENCE WHEN CLEANING, CUSTOMER SHOULD INSTALL WATER TAP NEAR MACHINE WITH 30 FT. OF HEAVY DUTY HOSE WITH SQUEEZE VALVE.
THIS DRAWING IS SUPPLIED AS A REFERENCE FOR CONNECTION INFORMATION ONLY. IT WILL NOT BE UTILIZED FOR MANUFACTURING OF UNIT.

ELECTRICAL WARNING:

SERVICE WIRE TEMPERATURE RATING: 90C.

PLUMBING NOTES:

- RECOMMENDED WATER HARDNESS TO BE 3 GRAINS OR LESS PER GALLON FOR BEST RESULTS.
- (b) RECOMMENDED BUILDING FLOWING HOT WATER PRESSURE TO THE DISHWASHER IS 40-45 PSI.
- (c) RECOMMENDED BUILDING FLOWING COLD WATER PRESSURE TO THE DISHWASHER IS 30-35 PSI. IF COLD WATER IS LESS THAN 55°F CONTACT SALES ENGINEERING.
- (d) WATER HAMMER ARRESTOR (MEETING ASSE-1010 STANDARD OR EQUIVALENT) TO BE SUPPLIED (BY OTHERS) IN HOT AND COLD WATER SUPPLY LINES AT SERVICE CONNECTION.

VENTILATION NOTES:

- (e) THE VENT STACK AND ITS ENCLOSURE CAN BE TEMPORARILY REMOVED FROM THE ENERGY RECOVERY UNIT TO YIELD 81-7/8" CLEARANCE FOR DOORWAYS.

ELECTRICAL CONNECTIONS COMMON ON ALL MODELS:

- E1 ELECTRIC CONNECTION, DETERGENT AND RINSE FEEDERS (MACHINE SERVICE VOLTAGE), 1/2" CONDUIT. 79-1/8" AFF
- E2 ELECTRIC CONNECTION, VENT FAN CONTROL. (SWITCH CONTACTS) 1/2" CONDUIT. 79-1/8" AFF

ELECTRICAL CONNECTIONS W/O CIRCUIT BREAKERS:

- E3 ELECTRIC CONNECTION, MOTORS & CONTROLS, 1" CONDUIT. 79-1/8" AFF
- E4 ELECTRIC TANK HEAT CONNECTION, WASH TANK, 36KW. 1-1/4" CONDUIT. 79-1/8" AFF
- E5 ELECTRIC TANK HEAT CONNECTION, DUAL RINSE TANK, 7KW. 1" CONDUIT. 79-1/8" AFF
- E6 ELECTRIC CONNECTION, BOOSTER, 18KW. 1" CONDUIT. 79-1/8" AFF

ELECTRICAL CONNECTIONS WITH CIRCUIT BREAKERS:

- E7 ELECTRIC CONNECTION, MOTORS, CONTROLS & BOOSTER HEAT (WHEN CIRCUIT BREAKER OPTION IS SPECIFIED). (TB1) 1-1/4" CONDUIT, 79-1/8" AFF
- E8 ELECTRIC CONNECTION, WASH HEAT & DUAL RINSE HEAT (TB2) 2" CONDUIT, 79-1/8" AFF

PLUMBING CONNECTIONS:

- P1 COMMON HOT WATER CONNECTION (AUTOMATIC FILL) 110°F WATER MINIMUM, 1" FPT, 5-1/2" AFF see notes (b) AND (d).
- P2 COMMON COLD WATER CONNECTION, 55°F WATER MINIMUM, 1" FPT, 5-1/2" AFF see notes (c) and (d).
- P3 COMMON DRAIN CONNECTION. TWO CONNECTION LOCATIONS; MAY BE DRAINED TO EITHER END OF UNIT, PLUG OPPOSITE END. 2" FPT. 7" AFF

VENTILATION REQUIREMENTS:

- V1 MINIMUM OF 24" SQUARE VENT HOOD WITH 6 INCH AIR GAP CAPABLE OF PROVIDING 750 CFM EXHAUST AT STANDARD AIR CONDITIONS (VENT HOOD SUPPLIED AND INSTALLED BY OTHERS). BACK DRAFT PREVENTER REQUIRED (SUPPLIED AND INSTALLED BY OTHERS). 95-3/8" AFF

MODEL:
FT1000S
ENERGY RECOVERY
ELECTRIC
L-R OPERATION
00-949513
REV A2

FT1000S ENERGY RECOVERY ELECTRIC R-L



701 S Ridge Avenue, Troy, OH 45374
1-888-4HOBART • www.hobartcorp.com

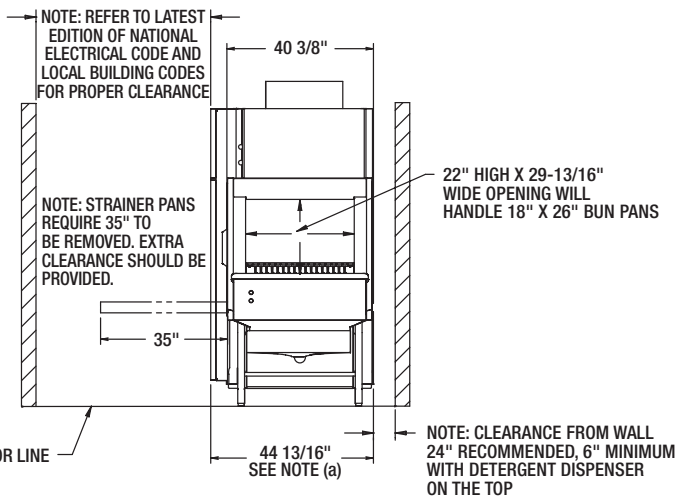
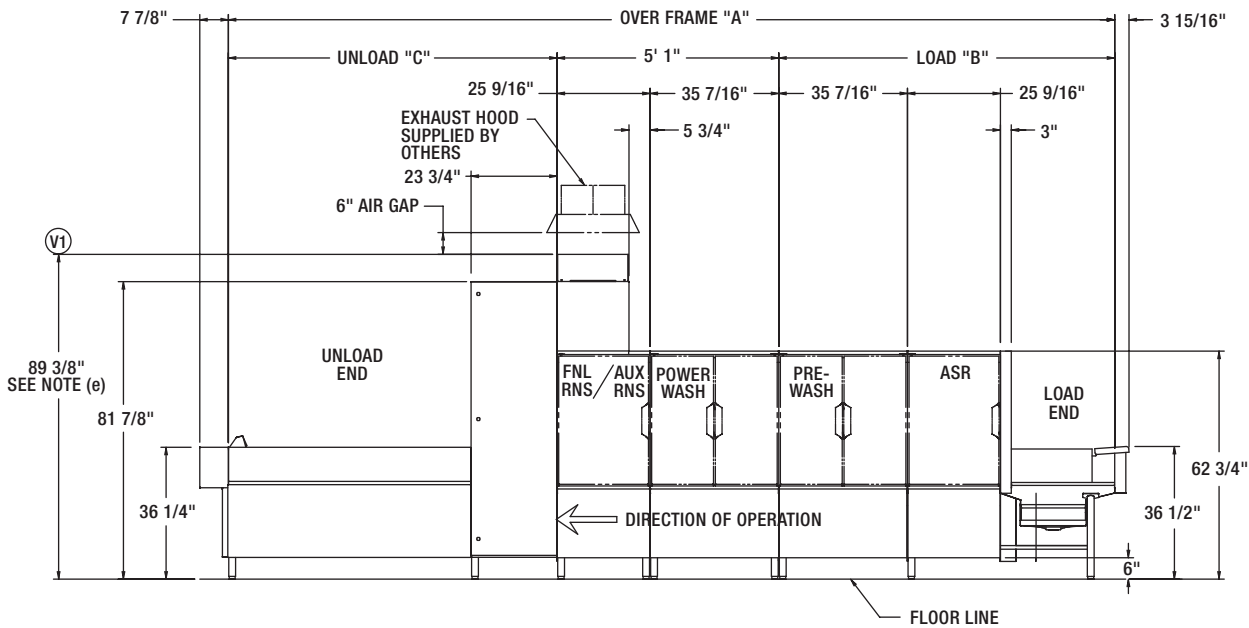
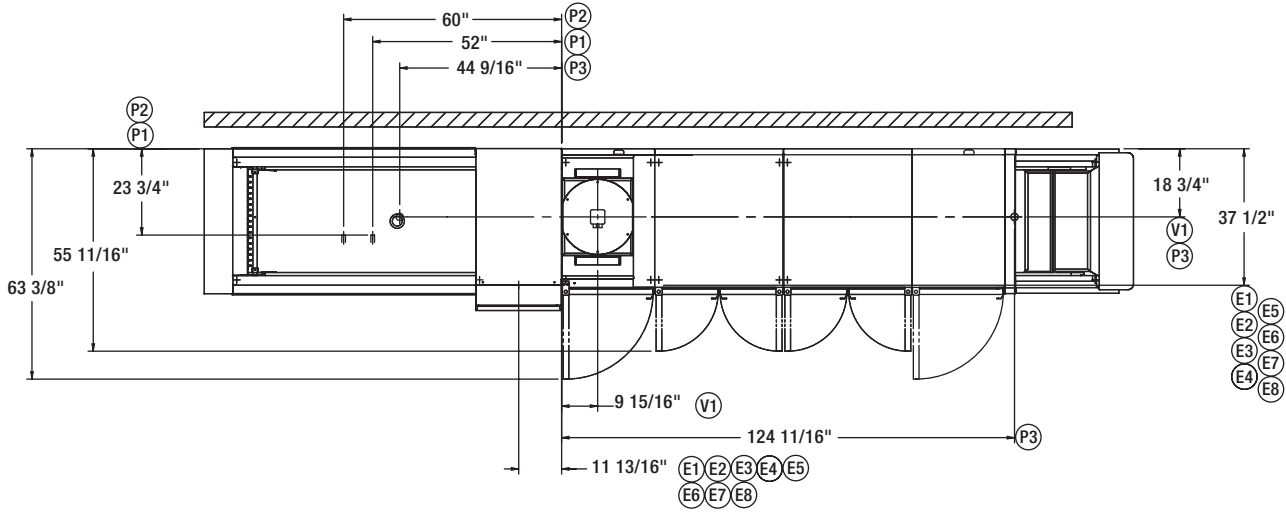

MODEL NO.	"A"	"B"	"C"
FT1018S (7.5'-5"-5.5')	18' 4-9/16"	7' 8-1/2"	5' 7"
FT1019S (8.5'-5"-5.5')	19' 4-5/16"	8' 8-1/4"	5' 7"
FT1020S (9.5'-5"-5.5')	20' 4-5/32"	9' 8-3/32"	5' 7"
FT1020S (7.5'-5"-7.5')	20' 4-1/16"	7' 8-1/2"	7' 6-1/2"
FT1021S (8.5'-5"-7.5')	21' 3-13/16"	8' 8-1/4"	7' 6-1/2"
FT1022S (9.5'-5"-7.5')	22' 3-21/32"	9' 8-3/32"	7' 6-1/2"
FT1022S (7.5'-5"-9')	21' 11-13/16"	7' 8-1/2"	9' 2-1/4"
FT1023S (8.5'-5"-9')	22' 11-9/16"	8' 8-1/4"	9' 2-1/4"
FT1024S (9.5'-5"-9')	23' 11-13/32"	9' 8-3/32"	9' 2-1/4"
FT1024S (7.5'-5"-11')	23' 11-7/16"	7' 8-1/2"	11' 1-7/8"
FT1025S (8.5'-5"-11')	24' 11-3/16"	8' 8-1/4"	11' 1-7/8"
FT1026S (9.5'-5"-11')	25' 11-1/32"	9' 8-3/32"	11' 1-7/8"
FT1027S (7.5'-5"-15')	27' 6-3/4"	7' 8-1/2"	14' 9-3/16"
FT1028S (8.5'-5"-15')	28' 6-1/2"	8' 8-1/4"	14' 9-3/16"
FT1029S (9.5'-5"-15')	29' 6-11/32"	9' 8-3/32"	14' 9-3/16"
FT1029S (7.5'-5"-17')	29' 6-5/16"	7' 8-1/2"	16' 8-3/4"
FT1030S (8.5'-5"-17')	30' 6-1/16"	8' 8-1/4"	16' 8-3/4"
FT1031S (9.5'-5"-17')	31' 5-29/32"	9' 8-3/32"	16' 8-3/4"

NOTE: OVERALL LENGTH OF MACHINE IS DIMENSION "A" + 11 13/16"



701 S Ridge Avenue, Troy, OH 45374
1-888-4HOBART • www.hobartcorp.com

FT1000S ENERGY RECOVERY ELECTRIC R-L

SERVICE CONNECTION WITH CIRCUIT BREAKERS (2) SERVICE CONNECTIONS AS SHOWN BELOW			
MOTORS, CONTROLS & BOOSTER HEAT (TB1) (1) SERVICE CONNECTION AS SHOWN BELOW			
ELEC. SPECS.	RATED AMPS	MINIMUM SUPPLY CONDUCTOR AMPACITY	MAXIMUM PROTECTIVE DEVICES
208/60/3	87.7	125	125
240/60/3	85.2	125	125
480/60/3	47.9	60	60
WASH, DUAL RINSE HEAT (TB2) (1) SERVICE CONNECTION AS SHOWN BELOW			
ELEC. SPECS.	RATED AMPS	MINIMUM SUPPLY CONDUCTOR AMPACITY	MAXIMUM PROTECTIVE DEVICE
208/60/3	129.0	175	175
240/60/3	123.2	150	150
480/60/3	61.5	80	80

SERVICE CONNECTION W/O CIRCUIT BREAKERS (4) SERVICE CONNECTIONS AS SHOWN BELOW			
ELECTRIC TANK HEAT, DUAL RINSE (1) 7 KW CONNECTION AS SHOWN BELOW			
ELEC. SPECS.	RATED AMPS	MINIMUM SUPPLY CONDUCTOR AMPACITY	MAXIMUM PROTECTIVE DEVICES
208/60/3	21.0	25	25
240/60/3	20.0	25	25
480/60/3	10.0	15	15

ELECTRIC TANK HEAT, WASH (1) 36 KW CONNECTION AS SHOWN BELOW			
ELEC. SPECS.	RATED AMPS	MINIMUM SUPPLY CONDUCTOR AMPACITY	MAXIMUM PROTECTIVE DEVICES
208/60/3	108.0	125	125
240/60/3	103.2	125	125
480/60/3	51.5	70	70

ELECTRIC BOOSTER (1) 18 KW CONNECTION AS SHOWN BELOW			
ELEC. SPECS.	RATED AMPS	MINIMUM SUPPLY CONDUCTOR AMPACITY	MAXIMUM PROTECTIVE DEVICES
208/60/3	54.0	70	70
240/60/3	51.5	70	70
480/60/3	25.8	35	35

MOTORS AND CONTROLS (1) SERVICE CONNECTION AS SHOWN BELOW			
ELEC. SPECS.	RATED AMPS	MINIMUM SUPPLY CONDUCTOR AMPACITY	MAXIMUM PROTECTIVE DEVICE
208-240/60/3	33.7	45	45
480/60/3	22.1	30	30

⚠ WARNING

Electrical and grounding connections must comply with the applicable portions of the National Electrical Code and/or other local electrical codes.

Plumbing connections must comply with applicable sanitary, safety and plumbing codes. Drain and fill line configurations vary, some methods are shown on this drawing.

NOTICE

Pressure gauge not required on pumped rinse machines.

GENERAL NOTES:

- (a) THE CONTROL BOX IS ATTACHED TO THE CENTER SECTION AND IS ROTATED 90 DEGREES FOR SHIPPING.
AFF = ABOVE FINISHED FLOOR
ALL DIMENSIONS TAKEN FROM THE FLOOR LINE MAY INCREASE 3-1/4" WITH LEG ADJUSTMENT.
FOR CONVENIENCE WHEN CLEANING, CUSTOMER SHOULD INSTALL WATER TAP NEAR MACHINE WITH 30 FT. OF HEAVY DUTY HOSE WITH SQUEEZE VALVE.
THIS DRAWING IS SUPPLIED AS A REFERENCE FOR CONNECTION INFORMATION ONLY. IT WILL NOT BE UTILIZED FOR MANUFACTURING OF UNIT.

ELECTRICAL WARNING:

SERVICE WIRE TEMPERATURE RATING: 90C.

PLUMBING NOTES:

- RECOMMENDED WATER HARDNESS TO BE 3 GRAINS OR LESS PER GALLON FOR BEST RESULTS.
- (b) RECOMMENDED BUILDING FLOWING HOT WATER PRESSURE TO THE DISHWASHER IS 40-45 PSI.
- (c) RECOMMENDED BUILDING FLOWING COLD WATER PRESSURE TO THE DISHWASHER IS 30-35 PSI. IF COLD WATER IS LESS THAN 55°F CONTACT SALES ENGINEERING.
- (d) WATER HAMMER ARRESTOR (MEETING ASSE-1010 STANDARD OR EQUIVALENT) TO BE SUPPLIED (BY OTHERS) IN HOT AND COLD WATER SUPPLY LINES AT SERVICE CONNECTION.

VENTILATION NOTES:

- (e) THE VENT STACK AND ITS ENCLOSURE CAN BE TEMPORARILY REMOVED FROM THE ENERGY RECOVERY UNIT TO YIELD 81-7/8" CLEARANCE FOR DOORWAYS.

ELECTRICAL CONNECTIONS COMMON ON ALL MODELS:

- E1 ELECTRIC CONNECTION, DETERGENT AND RINSE FEEDERS (MACHINE SERVICE VOLTAGE), 1/2" CONDUIT. 79-1/8" AFF
- E2 ELECTRIC CONNECTION, VENT FAN CONTROL. (SWITCH CONTACTS) 1/2" CONDUIT. 79-1/8" AFF

ELECTRICAL CONNECTIONS W/O CIRCUIT BREAKERS:

- E3 ELECTRIC CONNECTION, MOTORS & CONTROLS, 1" CONDUIT. 79-1/8" AFF
- E4 ELECTRIC TANK HEAT CONNECTION, WASH TANK, 36KW. 1-1/4" CONDUIT. 79-1/8" AFF
- E5 ELECTRIC TANK HEAT CONNECTION, DUAL RINSE TANK, 7KW. 1" CONDUIT. 79-1/8" AFF
- E6 ELECTRIC CONNECTION, BOOSTER, 18KW. 1" CONDUIT. 79-1/8" AFF

ELECTRICAL CONNECTIONS WITH CIRCUIT BREAKERS:

- E7 ELECTRIC CONNECTION, MOTORS, CONTROLS & BOOSTER HEAT (WHEN CIRCUIT BREAKER OPTION IS SPECIFIED). (TB1) 1-1/4" CONDUIT, 79-1/8" AFF
- E8 ELECTRIC CONNECTION, WASH HEAT & DUAL RINSE HEAT (TB2) 2" CONDUIT, 79-1/8" AFF

PLUMBING CONNECTIONS:

- P1 COMMON HOT WATER CONNECTION (AUTOMATIC FILL) 110°F WATER MINIMUM, 1" FPT, 5-1/2" AFF see notes (b) AND (d).
- P2 COMMON COLD WATER CONNECTION, 55°F WATER MINIMUM, 1" FPT, 5-1/2" AFF see notes (c) and (d).
- P3 COMMON DRAIN CONNECTION. TWO CONNECTION LOCATIONS; MAY BE DRAINED TO EITHER END OF UNIT, PLUG OPPOSITE END. 2" FPT. 7" AFF

VENTILATION REQUIREMENTS:

- V1 MINIMUM OF 24" SQUARE VENT HOOD WITH 6 INCH AIR GAP CAPABLE OF PROVIDING 750 CFM EXHAUST AT STANDARD AIR CONDITIONS (VENT HOOD SUPPLIED AND INSTALLED BY OTHERS). BACK DRAFT PREVENTER REQUIRED (SUPPLIED AND INSTALLED BY OTHERS). 95-3/8" AFF

MODEL:
FT1000S
ENERGY RECOVERY
ELECTRIC
R-L OPERATION
00-949512
REV A2

FT1000S ENERGY RECOVERY STEAM L-R



701 S Ridge Avenue, Troy, OH 45374
1-888-4HOBART • www.hobartcorp.com

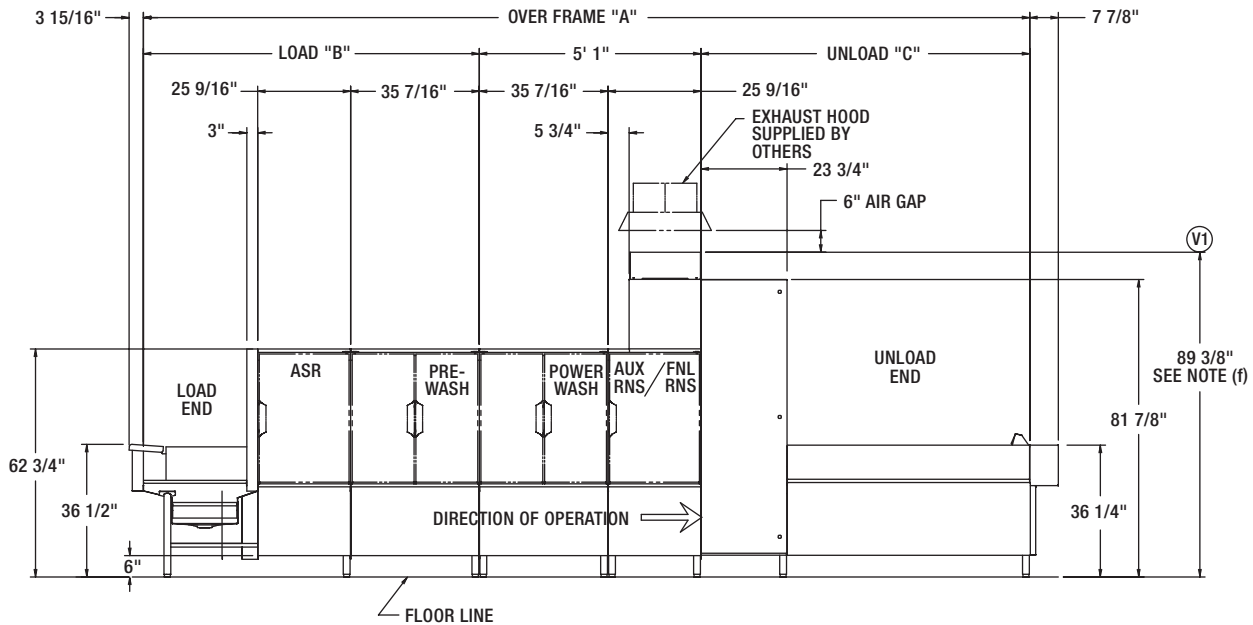
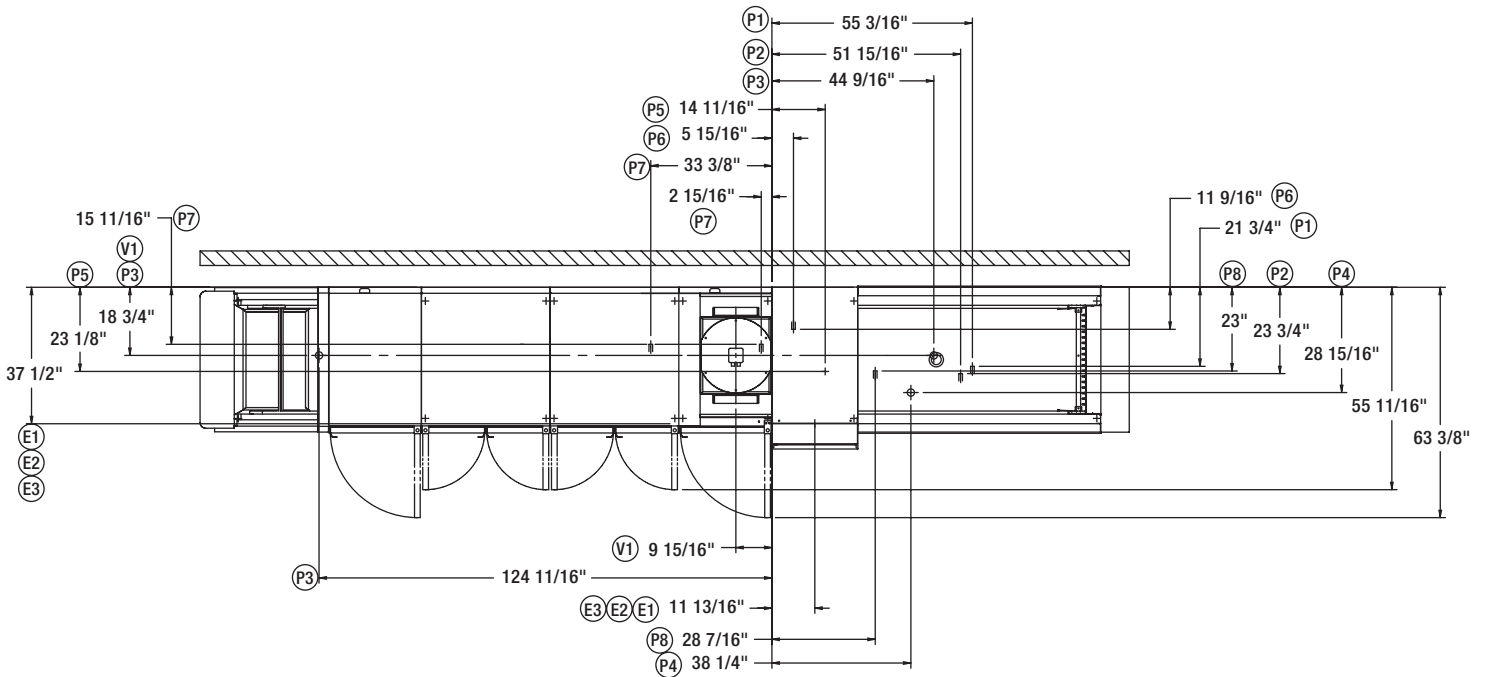

⚠ WARNING

Electrical and grounding connections must comply with the applicable portions of the National Electrical Code and/or other local electrical codes.

Plumbing connections must comply with applicable sanitary, safety and plumbing codes. Drain and fill line configurations vary, some methods are shown on this drawing.

NOTICE

Pressure gauge not required on pumped rinse machines.



701 S Ridge Avenue, Troy, OH 45374
1-888-4HOBART • www.hobartcorp.com

FT1000S ENERGY RECOVERY STEAM L-R

SERVICE CONNECTION WITH & W/O CIRCUIT BREAKERS (1) SERVICE CONNECTION AS SHOWN BELOW			
MOTORS AND CONTROLS			
ELEC. SPECS.	RATED AMPS	MINIMUM SUPPLY CONDUCTOR AMPACITY	MAXIMUM PROTECTIVE DEVICE
208-240/60/3	33.7	45	45
480/60/3	22.1	30	30

MODEL NO.	"A"	"B"	"C"
FT1018S (7.5'-5"-5.5')	18' 4-9/16"	7' 8-1/2"	5' 7"
FT1019S (8.5'-5"-5.5')	19' 4-5/16"	8' 8-1/4"	5' 7"
FT1020S (9.5'-5"-5.5')	20' 4-5/32"	9' 8-3/32"	5' 7"
FT1020S (7.5'-5"-7.5')	20' 4-1/16"	7' 8-1/2"	7' 6-1/2"
FT1021S (8.5'-5"-7.5')	21' 3-13/16"	8' 8-1/4"	7' 6-1/2"
FT1022S (9.5'-5"-7.5')	22' 3-21/32"	9' 8-3/32"	7' 6-1/2"
FT1022S (7.5'-5"-9')	21' 11-13/16"	7' 8-1/2"	9' 2-1/4"
FT1023S (8.5'-5"-9')	22' 11-9/16"	8' 8-1/4"	9' 2-1/4"
FT1024S (9.5'-5"-9')	23' 11-13/32"	9' 8-3/32"	9' 2-1/4"
FT1024S (7.5'-5"-11')	23' 11-7/16"	7' 8-1/2"	11' 1-7/8"
FT1025S (8.5'-5"-11')	24' 11-3/16"	8' 8-1/4"	11' 1-7/8"
FT1026S (9.5'-5"-11')	25' 11-1/32"	9' 8-3/32"	11' 1-7/8"
FT1027S (7.5'-5"-15')	27' 6-3/4"	7' 8-1/2"	14' 9-3/16"
FT1028S (8.5'-5"-15')	28' 6-1/2"	8' 8-1/4"	14' 9-3/16"
FT1029S (9.5'-5"-15')	29' 6-11/32"	9' 8-3/32"	14' 9-3/16"
FT1029S (7.5'-5"-17')	29' 6-5/16"	7' 8-1/2"	16' 8-3/4"
FT1030S (8.5'-5"-17')	30' 6-1/16"	8' 8-1/4"	16' 8-3/4"
FT1031S (9.5'-5"-17')	31' 5-29/32"	9' 8-3/32"	16' 8-3/4"

NOTE: OVERALL LENGTH OF MACHINE IS DIMENSION "A" + 11 13/16"

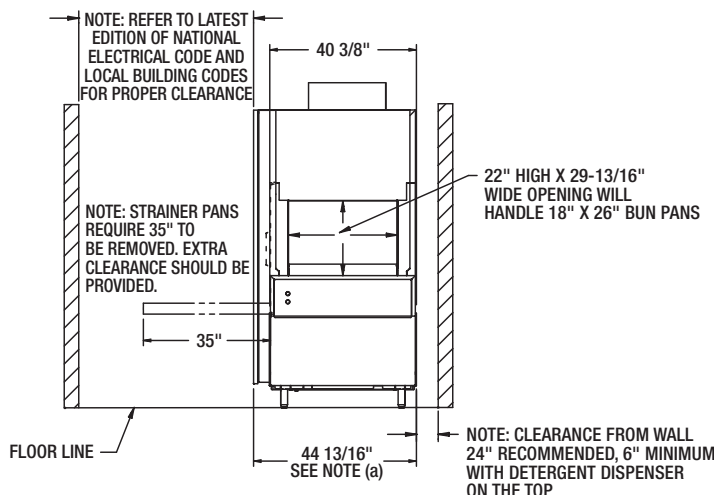

MODEL:
FT1000S ENERGY RECOVERY
STEAM
L-R OPERATION
00-949513
REV A2

GENERAL NOTES:

- (a) THE CONTROL BOX IS ATTACHED TO THE CENTER SECTION AND IS ROTATED 90 DEGREES FOR SHIPPING.
AFF = ABOVE FINISHED FLOOR
ALL DIMENSIONS TAKEN FROM THE FLOOR LINE MAY INCREASE 3-1/4" WITH LEG ADJUSTMENT.
FOR CONVENIENCE WHEN CLEANING, CUSTOMER SHOULD INSTALL WATER TAP NEAR MACHINE WITH 30 FT. OF HEAVY DUTY HOSE WITH SQUEEZE VALVE.
THIS DRAWING IS SUPPLIED AS A REFERENCE FOR CONNECTION INFORMATION ONLY. IT WILL NOT BE UTILIZED FOR MANUFACTURING OF UNIT.

ELECTRICAL WARNING:

SERVICE WIRE TEMPERATURE RATING: 90C.

PLUMBING NOTES:

- RECOMMENDED WATER HARDNESS TO BE 3 GRAINS OR LESS PER GALLON FOR BEST RESULTS.
- (b) RECOMMENDED BUILDING FLOWING HOT WATER PRESSURE TO THE DISHWASHER IS 40-45 PSI.
- (c) RECOMMENDED BUILDING FLOWING COLD WATER PRESSURE TO THE DISHWASHER IS 30-35 PSI. IF COLD WATER IS LESS THAN 55°F CONTACT SALES ENGINEERING.
- (d) WATER HAMMER ARRESTOR (MEETING ASSE-1010 STANDARD OR EQUIVALENT) TO BE SUPPLIED (BY OTHERS) IN HOT AND COLD WATER SUPPLY LINES AT SERVICE CONNECTION.
- (e) IF STEAM PRESSURE IS UNDER 10 PSI FLOWING PRESSURE AT THE DISHWASHER, CONTACT SALES ENGINEERING.

VENTILATION NOTES:

- (f) THE VENT STACK AND ITS ENCLOSURE CAN BE TEMPORARILY REMOVED FROM THE ENERGY RECOVERY UNIT TO YIELD 81-7/8" CLEARANCE FOR DOORWAYS.

ELECTRICAL CONNECTIONS COMMON ON ALL MODELS:

- E1 ELECTRIC CONNECTION, DETERGENT AND RINSE FEEDERS (MACHINE SERVICE VOLTAGE), 1/2" CONDUIT. 79-1/8" AFF
- E2 ELECTRIC CONNECTION, VENT FAN CONTROL. (SWITCH CONTACTS) 1/2" CONDUIT. 79-1/8" AFF

ELECTRICAL CONNECTIONS WITH & W/O CIRCUIT BREAKERS:

- E3 ELECTRIC CONNECTION, MOTORS & CONTROLS, 1" CONDUIT. 79-1/8" AFF

PLUMBING CONNECTIONS:

- P1 COMMON HOT WATER CONNECTION (AUTOMATIC FILL) 110°F WATER MINIMUM, 1" FPT, 5-1/2" AFF see notes (b) AND (d).
- P2 COMMON COLD WATER CONNECTION, 55°F WATER MINIMUM, 1" FPT, 5-1/2" AFF see notes (c) and (d).
- P3 COMMON DRAIN CONNECTION. TWO CONNECTION LOCATIONS; MAY BE DRAINED TO EITHER END OF UNIT, PLUG OPPOSITE END. 2" FPT, 7" AFF
- P4 COMMON STEAM CONNECTION (TANK HEAT & STEAM BOOSTER). 1-1/2" FPT, 4-3/8" AFF (10-45 PSI FLOWING PRESSURE) see note (e).
- P5 STEAM RELIEF VALVE, (WHEN STEAM BOOSTER OPTION IS SPECIFIED) 1" FPT, MUST BE PIPED TO OPEN DRAIN RECEIVER IN THE FLOOR. 16-15/16" AFF
- P6 HOT RELIEF VALVE, (WHEN STEAM BOOSTER OPTION IS SPECIFIED) 3/4" FPT, MUST BE PIPED TO OPEN DRAIN RECEIVER IN THE FLOOR. 15-9/16" AFF
- P7 CONDENSATE RETURN, GRAVITY CONNECTION (TANK HEAT), BUCKET TYPE TRAPS FURNISHED, 2 CONNECTIONS. 3/4" FPT, 11" AFF
- P8 CONDENSATE RETURN, GRAVITY CONNECTION (WHEN STEAM BOOSTER OPTION IS SPECIFIED), BUCKET TYPE TRAP FURNISHED. 3/4" FPT, 4-3/4" AFF

VENTILATION REQUIREMENTS:

- V1 MINIMUM OF 24" SQUARE VENT HOOD WITH 6 INCH AIR GAP CAPABLE OF PROVIDING 750 CFM EXHAUST AT STANDARD AIR CONDITIONS (VENT HOOD SUPPLIED AND INSTALLED BY OTHERS). BACK DRAFT PREVENTER REQUIRED (SUPPLIED AND INSTALLED BY OTHERS). 95-3/8" AFF

FT1000S ENERGY RECOVERY STEAM R-L



701 S Ridge Avenue, Troy, OH 45374
1-888-4HOBART • www.hobartcorp.com

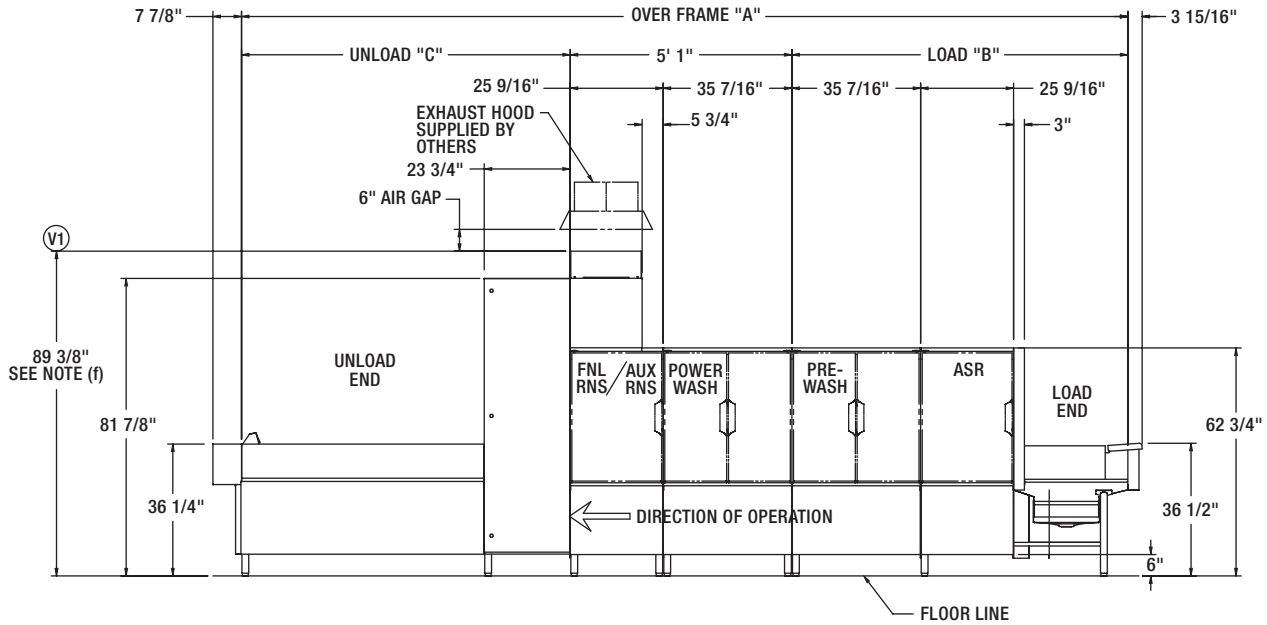
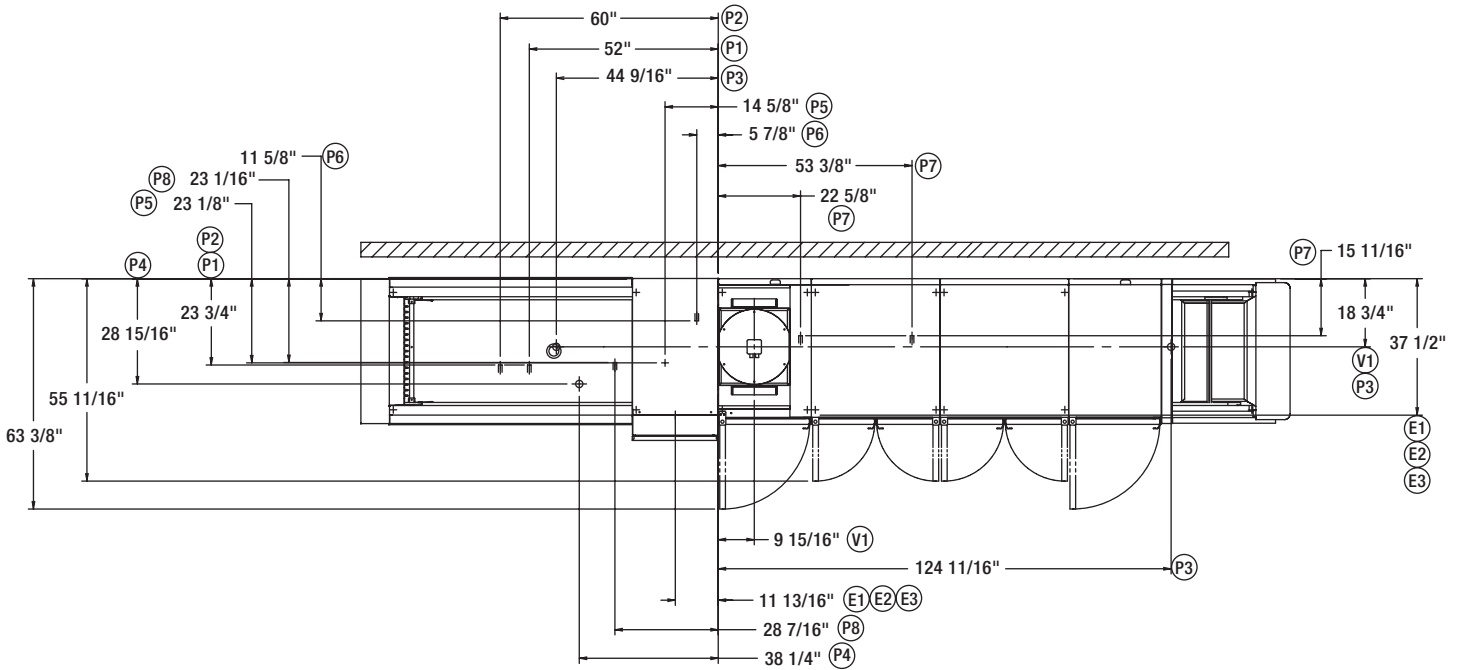

⚠ WARNING

Electrical and grounding connections must comply with the applicable portions of the National Electrical Code and/or other local electrical codes.

Plumbing connections must comply with applicable sanitary, safety and plumbing codes. Drain and fill line configurations vary, some methods are shown on this drawing.

NOTICE

Pressure gauge not required on pumped rinse machines.



701 S Ridge Avenue, Troy, OH 45374
1-888-4HOBART • www.hobartcorp.com

FT1000S ENERGY RECOVERY STEAM R-L

SERVICE CONNECTION WITH & W/O CIRCUIT BREAKERS (1) SERVICE CONNECTION AS SHOWN BELOW			
MOTORS AND CONTROLS			
ELEC. SPECS.	RATED AMPS	MINIMUM SUPPLY CONDUCTOR AMPACITY	MAXIMUM PROTECTIVE DEVICE
208-240/60/3	33.7	45	45
480/60/3	22.1	30	30

MODEL NO.	"A"	"B"	"C"
FT1018S (7.5'-5"-5.5')	18' 4-9/16"	7' 8-1/2"	5' 7"
FT1019S (8.5'-5"-5.5')	19' 4-5/16"	8' 8-1/4"	5' 7"
FT1020S (9.5'-5"-5.5')	20' 4-5/32"	9' 8-3/32"	5' 7"
FT1020S (7.5'-5"-7.5')	20' 4-1/16"	7' 8-1/2"	7' 6-1/2"
FT1021S (8.5'-5"-7.5')	21' 3-13/16"	8' 8-1/4"	7' 6-1/2"
FT1022S (9.5'-5"-7.5')	22' 3-21/32"	9' 8-3/32"	7' 6-1/2"
FT1022S (7.5'-5"-9')	21' 11-13/16"	7' 8-1/2"	9' 2-1/4"
FT1023S (8.5'-5"-9')	22' 11-9/16"	8' 8-1/4"	9' 2-1/4"
FT1024S (9.5'-5"-9')	23' 11-13/32"	9' 8-3/32"	9' 2-1/4"
FT1024S (7.5'-5"-11')	23' 11-7/16"	7' 8-1/2"	11' 1-7/8"
FT1025S (8.5'-5"-11')	24' 11-3/16"	8' 8-1/4"	11' 1-7/8"
FT1026S (9.5'-5"-11')	25' 11-13/32"	9' 8-3/32"	11' 1-7/8"
FT1027S (7.5'-5"-15')	27' 6-3/4"	7' 8-1/2"	14' 9-3/16"
FT1028S (8.5'-5"-15')	28' 6-1/2"	8' 8-1/4"	14' 9-3/16"
FT1029S (9.5'-5"-15')	29' 6-11/32"	9' 8-3/32"	14' 9-3/16"
FT1029S (7.5'-5"-17')	29' 6-5/16"	7' 8-1/2"	16' 8-3/4"
FT1030S (8.5'-5"-17')	30' 6-1/16"	8' 8-1/4"	16' 8-3/4"
FT1031S (9.5'-5"-17')	31' 5-29/32"	9' 8-3/32"	16' 8-3/4"

NOTE: OVERALL LENGTH OF MACHINE IS DIMENSION "A" + 11 13/16"

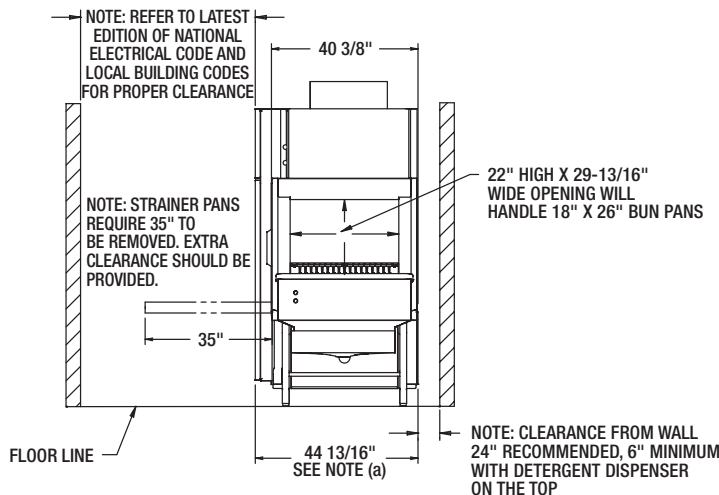

MODEL:
FT1000S ENERGY RECOVERY
STEAM
R-L OPERATION
00-949512
REV A2

GENERAL NOTES:

- (a) THE CONTROL BOX IS ATTACHED TO THE CENTER SECTION AND IS ROTATED 90 DEGREES FOR SHIPPING.
AFF = ABOVE FINISHED FLOOR
ALL DIMENSIONS TAKEN FROM THE FLOOR LINE MAY INCREASE 3-1/4" WITH LEG ADJUSTMENT.
FOR CONVENIENCE WHEN CLEANING, CUSTOMER SHOULD INSTALL WATER TAP NEAR MACHINE WITH 30 FT. OF HEAVY DUTY HOSE WITH SQUEEZE VALVE.
THIS DRAWING IS SUPPLIED AS A REFERENCE FOR CONNECTION INFORMATION ONLY. IT WILL NOT BE UTILIZED FOR MANUFACTURING OF UNIT.

ELECTRICAL WARNING:

SERVICE WIRE TEMPERATURE RATING: 90C.

PLUMBING NOTES:

- RECOMMENDED WATER HARDNESS TO BE 3 GRAINS OR LESS PER GALLON FOR BEST RESULTS.
- (b) RECOMMENDED BUILDING FLOWING HOT WATER PRESSURE TO THE DISHWASHER IS 40-45 PSI.
- (c) RECOMMENDED BUILDING FLOWING COLD WATER PRESSURE TO THE DISHWASHER IS 30-35 PSI. IF COLD WATER IS LESS THAN 55°F CONTACT SALES ENGINEERING.
- (d) WATER HAMMER ARRESTOR (MEETING ASSE-1010 STANDARD OR EQUIVALENT) TO BE SUPPLIED (BY OTHERS) IN HOT AND COLD WATER SUPPLY LINES AT SERVICE CONNECTION.
- (e) IF STEAM PRESSURE IS UNDER 10 PSI FLOWING PRESSURE AT THE DISHWASHER, CONTACT SALES ENGINEERING.

VENTILATION NOTES:

- (f) THE VENT STACK AND ITS ENCLOSURE CAN BE TEMPORARILY REMOVED FROM THE ENERGY RECOVERY UNIT TO YIELD 81-7/8" CLEARANCE FOR DOORWAYS.

ELECTRICAL CONNECTIONS COMMON ON ALL MODELS:

- E1 ELECTRIC CONNECTION, DETERGENT AND RINSE FEEDERS (MACHINE SERVICE VOLTAGE), 1/2" CONDUIT. 79-1/8" AFF
- E2 ELECTRIC CONNECTION, VENT FAN CONTROL (SWITCH CONTACTS) 1/2" CONDUIT. 79-1/8" AFF

ELECTRICAL CONNECTIONS WITH & W/O CIRCUIT BREAKERS:

- E3 ELECTRIC CONNECTION, MOTORS & CONTROLS, 1" CONDUIT. 79-1/8" AFF

PLUMBING CONNECTIONS:

- P1 COMMON HOT WATER CONNECTION (AUTOMATIC FILL) 110°F WATER MINIMUM, 1" FPT, 5-1/2" AFF see notes (b) AND (d).
- P2 COMMON COLD WATER CONNECTION, 55°F WATER MINIMUM, 1" FPT, 5-1/2" AFF see notes (c) and (d).
- P3 COMMON DRAIN CONNECTION. TWO CONNECTION LOCATIONS; MAY BE DRAINED TO EITHER END OF UNIT, PLUG OPPOSITE END. 2" FPT, 7" AFF
- P4 COMMON STEAM CONNECTION (TANK HEAT & STEAM BOOSTER). 1-1/2" FPT, 4-3/8" AFF (10-45 PSI FLOWING PRESSURE) see note (e).
- P5 STEAM RELIEF VALVE, (WHEN STEAM BOOSTER OPTION IS SPECIFIED) 1" FPT, MUST BE PIPED TO OPEN DRAIN RECEIVER IN THE FLOOR. 16-15/16" AFF
- P6 HOT RELIEF VALVE, (WHEN STEAM BOOSTER OPTION IS SPECIFIED) 3/4" FPT, MUST BE PIPED TO OPEN DRAIN RECEIVER IN THE FLOOR. 15-9/16" AFF
- P7 CONDENSATE RETURN, GRAVITY CONNECTION (TANK HEAT), BUCKET TYPE TRAPS FURNISHED, 2 CONNECTIONS. 3/4" FPT, 11" AFF
- P8 CONDENSATE RETURN, GRAVITY CONNECTION (WHEN STEAM BOOSTER OPTION IS SPECIFIED), BUCKET TYPE TRAP FURNISHED. 3/4" FPT, 4-3/4" AFF

VENTILATION REQUIREMENTS:

- V1 MINIMUM OF 24" SQUARE VENT HOOD WITH 6 INCH AIR GAP CAPABLE OF PROVIDING 750 CFM EXHAUST AT STANDARD AIR CONDITIONS (VENT HOOD SUPPLIED AND INSTALLED BY OTHERS). BACK DRAFT PREVENTER REQUIRED (SUPPLIED AND INSTALLED BY OTHERS). 95-3/8" AFF

FT1000S ENERGY RECOVERY FLIGHT-TYPE DISHWASHER



701 S Ridge Avenue, Troy, OH 45374
1-888-4HOBART • www.hobartcorp.com

FT (flight type) Models—many additional variations of these model specifications are available. Engineering data furnished on request. Numbers in parentheses, after model number from left to right, represent length

in feet of the following respectively; Loading section, Washing and Power Rinsing sections, Unloading section.

FT1000S Energy Recovery Series (7.5, 9 Load / 5 Center / 5.5, 7.5, 9 Unload)	
Machine Ratings (Mechanical) Conveyor Speed — Feet per minute	4 - 6.3
Dishes per Hour	10,611
Motor — Horsepower	ASR Soil - ¼; ASR Wash - ½; Pre-Wash - ¾; Wash - 5; Dual Rinse - ½; Final Rinse - ½; Conveyor - ½
Tank Capacity — Gallons	ASR - 7.2; Pre-Wash - 40; Wash - 40; Dual Rinse - 7.2
Rate of Final Rinse — Gallons per minute (Pumped rinse)	.97
Final Rinse Consumption — Gallons per hour (Pumped rinse)	58
Exhaust Requirements — Cubic feet per minute	750 (at standard air conditions)
Latent/Sensible Heat — BTU per hour	Electric - Latent: 67,300 / Sensible: 28,900 Steam - Latent: 80,800 / Sensible: 34,600
Electric Heat Requirements — Tank Heat - Kilowatt (Regulated) Optional Electric Booster - Kilowatt	Disconnect switches are recommended for each power circuit connected to dishwasher. These disconnect switches are NOT furnished by Hobart and should be installed by the electrical contractor at the time of installation. Circuit breakers optional at extra cost. Total tank heat - 43KW (Wash and Dual Rinse) 18KW - 110°F incoming water raised to 185°F (75°F rise) (180°F minimum)
Steam Heat Requirements — Steam Consumption Tank Heat - Pounds per hour - maximum (Regulated) - based on 10 to 45 PSI steam at the machine Optional Steam Booster - Pounds per hour - maximum - based on 20 PSI steam, 110°F incoming water raised to 185°F (75°F rise) (180°F minimum)	171 lbs./160°F Wash minimum - 160°F Dual Rinse minimum 42 lbs./180°F Final Rinse minimum
Peak Rate of Drain Flow — Gallons per minute Initial rate with full tanks	38
Shipping Weight Crated	Varies by individual model - consult your Hobart representative

As continued product improvement is a policy of Hobart, specifications are subject to change without notice.