

# WORKTOP FREEZER (0°F)

**Model: SWF27-D**

## 27" Worktop Freezer with Drawers

Stainless steel front and top, aluminum end panels, case back and interior.

**Designed to maintain NSF-7 temperatures in 100°F ambient.**



### Options and Accessories

(upcharge and lead times may apply)

Stainless steel exterior and interior	Adjustable legs
Stainless back in lieu of aluminum	Remote models
Overshelves (single or double)	Drawers locks
Door in lieu of drawers	Stacking collar
Backsplash - BS models	Special electrical requirements (consult factory)

Consult factory for other model configurations, options and accessories.

**Continental**  
Refrigerator

Toll-Free: 800-523-7138  
Phone: 215-244-1400  
Fax: 215-244-9579

539 Dunksferry Road  
Bensalem, PA 19020  
[www.continentalrefrigerator.com](http://www.continentalrefrigerator.com)

Project Name:

Model Specified:

Location:

Item No:

Quantity:

AIA #:

SIS #:

### Standard Model Features

#### REFRIGERATION SYSTEM

Performance-rated refrigeration system  
Environmentally-safe R-134a refrigerant  
Automatic, hot gas condensate evaporator  
Non-corrosive, plasticized fin evaporator coil  
Easily serviceable back mounted compressor

#### CABINET ARCHITECTURE

2" non-CFC polyurethane foam insulation  
Stainless steel roll-out drawers  
Magnetic snap-in drawer gaskets  
Completely enclosed, vented and removable case back  
5" casters

#### MODEL FEATURES

Interior digital thermometer  
Automatic electric defrost  
Expansion valve system

APPROVAL:

## Model Specifications

### DIMENSIONAL DATA

Net Capacity (cu. ft.)	7.4 (210 cu l)
Width, Overall (in.)	27 1/2 (699 mm)
Depth, Overall (in.) (incl. handle & bumpers)	31 7/16 (799 mm)
Depth, Body Only (less drawers) (in.)	27 1/2 (699 mm)
Height, Overall (in.) (incl. 5" casters)	35 1/4 (895 mm)
No. of Drawers (two tier)	2
No. of Drawers (three tier)	3

### REFRIGERANT DATA

Condensing Unit Size (H.P.)	1/4
Capacity (BTU/Hr)*	1325

### ELECTRICAL DATA

Voltage (int'l)	115/60/1 (n/a)
Fans	1
Total Amps (int'l)	4.8 (n/a)
Defrost Amps (int'l)	5.7 (n/a)
10 ft. Cord/Plug [attached] (int'l)	Yes (n/a)

### SHIPPING DATA

Weight (lbs.)	165 (75 kg)
Height - Crated (in.)	43 1/4 (1099 mm)
Width - Crated (in.)	35 3/4 (908 mm)
Depth - Crated (in.)	37 1/4 (946 mm)

### DRAWER PAN CONFIGURATIONS

**Two Tier:** (1) 12 x 20 x 6 pan per drawer

**Three Tier:** (1) 12 x 20 x 4 pan per drawer

\* Rating @ -15°F evaporator, 90°F ambient

Figures in parentheses reflect metric equivalents rounded to the nearest whole unit.



Equipped with one NEMA-5-15P Plug  
(varies by country)

## Model Plan Views

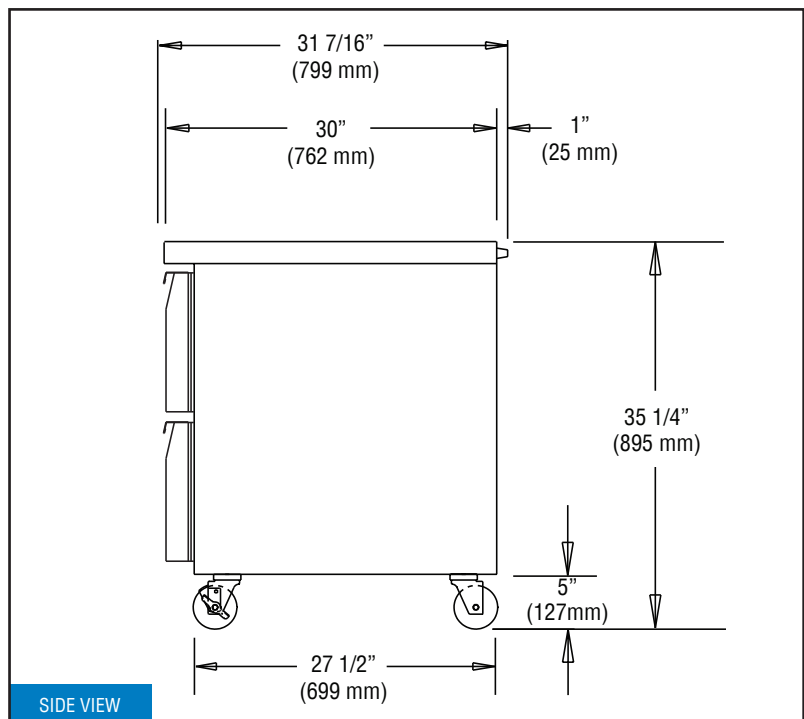
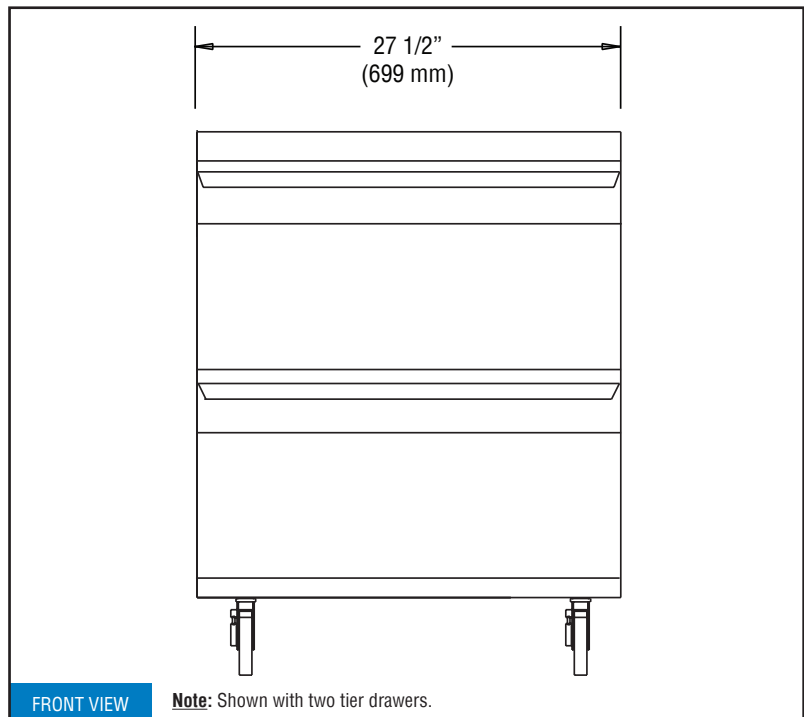

# Continental

Refrigerator

Toll-Free: 800-523-7138  
Phone: 215-244-1400  
Fax: 215-244-9579

539 Dunkserry Road  
Bensalem, PA 19020  
[www.continentalrefrigerator.com](http://www.continentalrefrigerator.com)

Due to our continued efforts in developing innovative products, specifications subject to change without notice.



MADE IN THE U.S.A.

© Copyright 2015. Continental Refrigerator.  
A Division of National Refrigeration & Air Conditioning Products, Inc.