

Utility Raceways E Series model EID

Description:

The E-series Raceway is a bus bar Utility Distribution System comprised of a stainless steel sheet metal housing enclosing electrical and plumbing services that provide connections for individual appliances. Raceways with plumbing services are Listed by Underwriters Laboratories (UL) as Commercial Appliance Outlet Centers. Raceways with only electrical services are Listed by UL as Multi-outlet Assemblies. These raceways are intended primarily for use with cooking batteries, or cooking appliance line-ups, on both sides of the Raceway, or with appliances along one side and an aisle on the other side. Individual Point-of-use connection plates are located on the bottom along the length of the raceway.

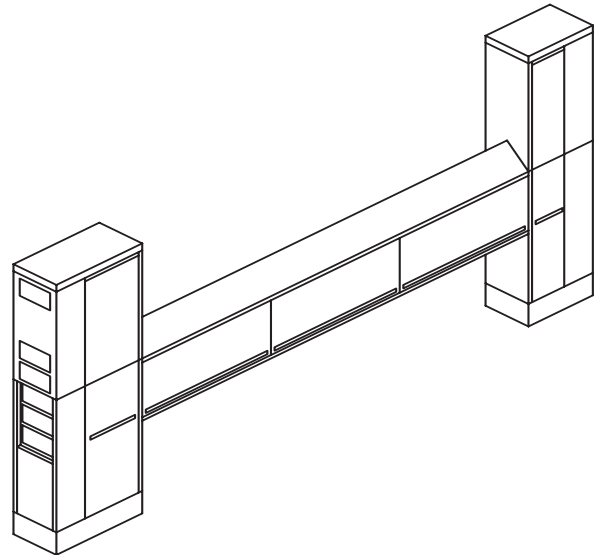

Specifications:

Dimensions: Horizontal Chase Width: 12", Height: 18" – 30" plus 6" peaked top, Length: as required. Service Towers Width: 12" Height: Finished Floor to Exhaust Hood or Finished Ceiling, Length: 18" Nominal to 42" Nominal. Intermediate Pedestals Width: 10" Height: Finished Floor to bottom of Horizontal Chase, Length: 10". **Construction:** 300-series Stainless Steel. Removable panels held in place with threaded fasteners. **Electrical Data:** 50 to 1000 amperes. 120/208-240 volt to 480 volts. Single- or three-phase. (600 volt maximum). **Water:** 150 psig & 140° F (60° C) maximum. **Steam:** 150 psig & 289° F (143° C) maximum. **Gas (Natural gas or LP):** 1.25 psig.

Standard Features:

- Point-of-use branch circuit protection with receptacle or flexible liquid tight metal conduit (pigtail) mounted adjacent to Point-of-use branch circuit protection on 5x9" connection plate
- Ground fault circuit interrupter for 15 & 20 amp, 120/1, straight blade receptacles
- Copper hot and cold water supply lines, if required
- Black iron gas supply line, if required
- Black iron steam supply and condensate return lines, if required
- Quarter-turn shut-off valves on all individual connections
- 2" High collar at top of service tower allows $\pm 1/2$ " vertical adjustment to compensate for floor and/or exhaust hood mounting irregularities
- Hinged cover over point-of-use circuit breaker
- Condensate purging system-on raceways with steam supply lines, a strainer and steam trap allows condensate to continuously bleed from the steam supply line. Condensate can be routed to the condensate return line inside the raceway, or to an open floor drain.

Optional Accessories:

- Ground fault equipment protection
 - Main electrical service circuit breaker with shunt trip
 - Remote status indicator lights dual-colored LED indicates whether point-of-use branch circuit breaker is on (green) or off (red)
 - Dual-colored circuit breaker indicator light (LED) on individual point-of-use connection plates
 - Quick-disconnect fittings for individual gas connections
 - Quick-disconnect fittings for individual water connections in addition to quarter-turn shut-off valves for movable appliances
 - Vent light switch in service tower
 - Vent light switch with circuit breaker in service tower(s)
 - Duplex convenience outlet in service tower(s)
 - Ventilation system control panel
 - 24-Hour timer for remotely located, motorized shut-off valve on steam supply
 - Gas delay reset (GDRI)
 - 120 V AC fire-fuel shut-off solenoid valve(s) for gas supply. 1 1/2" And smaller located in service tower(s)
- (2" and larger are remotely located)
- Fire-fuel shunt trip on individual point-of-use circuit breakers
 - Temperature/pressure gauge at water incoming service location
 - Gas delay reset (GDRIB)
 - 24V DC gas solenoid in lieu of 120V AC
 - Security package (includes):
 - exposed fasteners to be tamper-resistant, pin-in-head torx-head, shipped loose and installed in field
 - hinged doors equipped with eye for customer-supplied padlock
 - Stainless steel "clean steam" supply and return lines
 - Dormer or tower mounted faucet or pot filler
 - Dormer mounted point-of-use connection plate
 - Individual branch circuit protection (circuit breakers) located on 5x9" connection plates in control tower at end of raceway. Receptacles or pigtail located on 5x9" connection plates located along the length of the raceway. Vertical tower mounted bus bar distribution.
 - Filtered water system

Kettle/Braising Pan Arm Accessories:

- Manual water filling stations-single or double jointed swing faucet, or pot filler. Hot water, cold water, or mixed water available. 1/2" Or 3/4" NPT connections
- Electronic water meter-includes switch to allow unregulated water flow
- Manual steam control
- Electric steam control
- Electric cook/off/chill control
- Cooking timer

Front, Top & Side Views

