

Models □ XTRM-2 (1.5" opening) □ XTRM-2H (3" opening)

PRODUCT:

QUANTITY:

ITEM:

## Designed Smart

- The X\*treme™ -2 generates 800 slices of toast per hour.
- The X\*treme™ -2H generates 600 slices of toast per hour.
- X\*treme speed design combines new radiant heat system with our exclusive convection pre-heat system.
- Pre-heat convection system focuses hot air on bread in loading zone, pre-drying bread before toasting chamber.
- Air circulation system senses the perfect temperature in toaster cavity for the fastest startup.
- A variable speed control for the conveyor as well as controls top and bottom heating elements produce optimum results in toasting color and texture.
- Able to handle all types of breads, bagels or muffins.



Model X\*treme -2

## APW Wyott Design Features

- X\*treme Smarts (exclusive patent) protects employees from burns by keeping exteriors at X\*treme Cool temperatures. Circulation system keeps cooling air circulating in toaster, even after the power switch is turned off protecting components and exteriors from excessive residual heat.
- Self-dispensing bread drawer slides forward for removal of product.
- Superfeeder included.
- Removable reflector tray for ease in cleaning.
- High temperature bearings never require lubrication.
- Lighted main power rocker switch.
- Fully insulated.
- 1" adjustable legs.

## Options

- Stacking Kit (93000210)

## Reliability backed by APW Wyott's Warranty

All APW Wyott Heavy Toasters are backed by a 1-year parts and labor warranty, including on-site service calls within 50 miles of authorized service technicians.

•Certified by the following agencies:



See reverse side for product specifications.

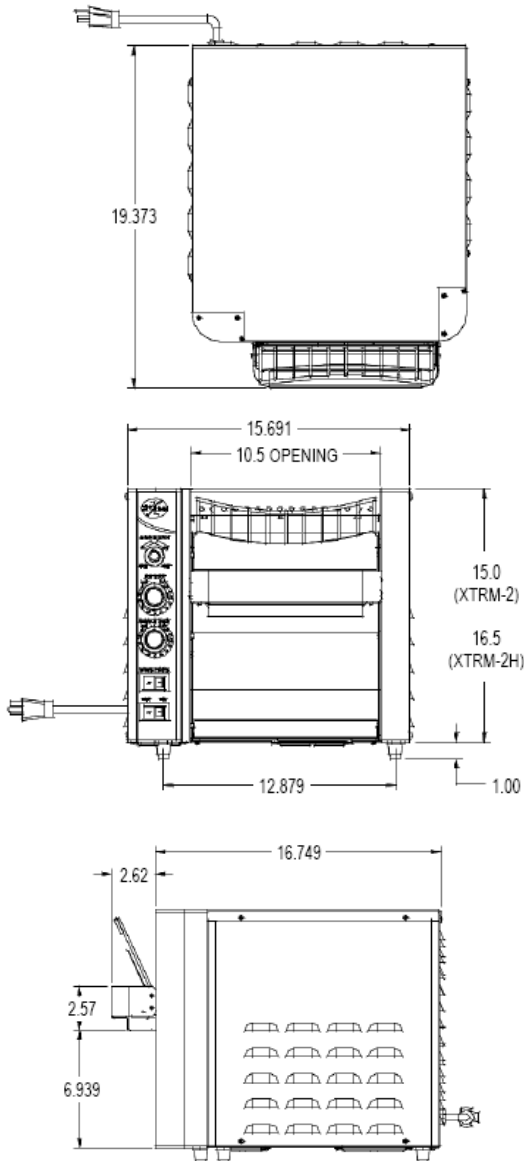

Model XTRM-2H is 1 1/2" higher

### PRODUCT SPECIFICATIONS:

#### Construction:

Stainless steel housing with painted aluminum front corners. Metal sheathed heating elements. Stainless steel wire conveyor belt. Painted stainless steel front heat guards. High temperature insulation protects control panel and exteriors.

#### Electrical Information:

Each unit is equipped with a 39", three wire grounded power cord which terminates with a standard three pronged male plug. The 208V/240V, use a NEMA 6-20P.

#### Electrical Specifications:

XTRM-2:	208V, 2840W, 13.6Amps
	240V, 2840W, 11.8Amps
	230V, 2840W, 12.3Amps
XTRM-2H:	208V, 2840W, 13.6Amps
	240V, 2840W, 11.8Amps
	230V, 2840W, 12.3Amps

#### Capacity:

XTRM-2:	800 slices per hour
XTRM-2H:	600 slices per hour

#### Overall Dimensions:

XTRM-2:	15" H x 15 5/8" W x 23 21/64"D
XTRM-2H:	16 1/2"H x 15 5/8"W x 23 21/64"D

Product opening height is 1 1/2" on the XTRM-2 and 3" on the XTRM-2H.

#### Shipping:

XTRM-2:	50 lbs.
XTRM-2H:	54 lbs

#### Freight Class: 100

FOB: Standex Dock

### Consultant Specifications

Toasters are constructed of stainless steel and aluminum material. Range of belt speeds should be 28 to 75 seconds. Front corners and front conveyor guard should be painted. Toasters furnished with 1" adjustable legs. Infrared metal sheathed radiant heaters are located on the top and bottom and are individually controlled by Infinite Heat Controls. On/Off switch has Indicator Light that glows when the toaster is on. Power saver switch will be supplied that reduces energy by 50%. Product opening is 1 1/2", motors are permanently lubricated. Toaster will be Air Cooled with a thermostatically controlled fan that stays on until the toaster is cool to the touch. Control area has cooling fan. Units are UL listed, UL Sanitation, and Canadian UL approved.

\*APW Wyott reserves the right to modify specifications or discontinue models without incurring obligation.