

Models □ XTRM-1 (120V) □ XTRM-1 (208 V) □ XTRM-1 (240V) □ XTRM-1 (230V)

PRODUCT:

QUANTITY:

ITEM:

Designed Smart

- The X*treme™ -1 generates over 350 slices of toast per hour.
- Designed to fit into tight space areas on counters.
- Toasters have extended super feeder and warming area to allow for high volume productions.
- Unique warming area keeps toast at the perfect temperature until you are ready to serve.
- A variable speed control for the conveyor produces optimum results in toaster color and texture.
- Able to handle a variety of breads, bagels or muffins.
- Protects your employees with “Cool Touch” exteriors...both sides and top surfaces.
- Conveyors and crumb trays are easily accessible and simple to clean.
- Removable side panel allows easy access for service.

APW Wyott Design Features

- Stainless steel housing with painted aluminum front corners.
- Small footprint fits into tight counter space.
- Insulated and air cooled..
- Self-dispensing bread drawer slides forward for removal of product.
- Chrome coated wire feeder.
- Power saver switch reduces energy consumption by 50%.
- Handles on sides allow unit to be carried easier.
- Removable reflector tray.
- Variable speed control.
- One inch adjustable legs.



Model X*treme -1

Built Solid

- Stainless steel construction protects against kitchen wear and tear and rust.
- Metal sheathed heating elements offer enhanced durability and consumer safety vs. quartz tube heating elements.

Reliability backed by APW Wyott's Warranty

All APW Wyott X*treme Toasters are backed by a 2-year parts and labor warranty, including on-site service calls within 50 miles of authorized service technicians.

•Certified by the following agencies:



See reverse side for product specifications.

Models □ XTRM-1 (120V) □ XTRM-1 (208 V) □ XTRM-1 (240V) □ XTRM-1 (230V)

PRODUCT:

QUANTITY:

ITEM:

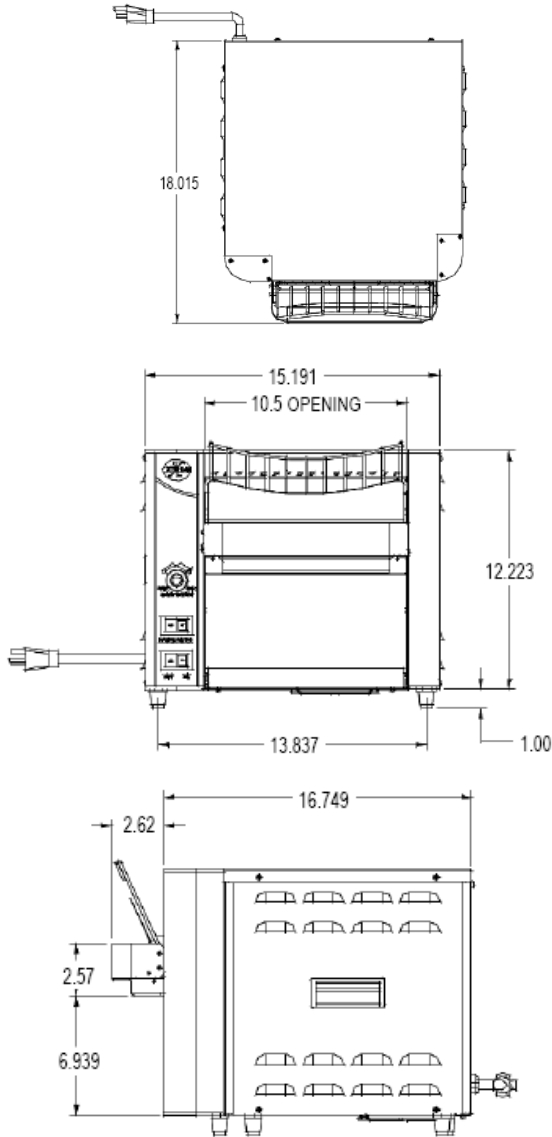

PRODUCT SPECIFICATIONS:

Construction:

Stainless steel housing augmented by front painted aluminum corners. Metal sheathed heating elements. Mirror polished stainless steel crumb tray. Polycarbonate handles on sides. Stainless steel front wire guard and "cool to the touch" protective shield. High temperature insulation protects control panel and exteriors.

Electrical Information:

Each unit is equipped with a 39", three wire grounded power cord which terminates with a standard three pronged male plug. The U.S. 120V units use a NEMA 5-15P plug and the Canadian 120V unit utilizes a 5-20P plug. The 208V, 240V and 230V all use a NEMA 6-20P.

Electrical Specifications;

120V, 1725W, 14.4 Amps
 208V, 1725W, 8.2 Amps
 240V, 1725, 7.2Amps
 Export 230V, 1725, 7.5Amps

Capacity:

350 slices per hour

Overall Dimensions:

13 1/4" H x 15 3/6" W x 17 3/4"D
 Product opening height is 1 1/2"

Shipping:

All units: 35 lbs.

Freight Class: 100

FOB: Standex Dock

Consultant Specifications

Toasters are constructed of stainless steel and aluminum material. Range of belt speeds should be 28 to 75 seconds. Front corners and front conveyor guard should be painted. Toasters furnished with 1" adjustable legs. Infrared metal sheathed radiant heaters are located on the top and bottom and are individually controlled by Infinite Heat Controls. On/Off switch has Indicator Light that glows when the toaster is on. Power saver switch will be supplied that reduces energy by 50%. Product opening is 1 1/2", motors are permanently lubricated. Toaster will be Air Cooled with a thermostatically controlled fan that stays on until the toaster is cool to the touch. Control area has cooling fan. Units are UL listed, UL Sanitation, and Canadian UL approved.

*APW Wyott reserves the right to modify specifications or discontinue models without incurring obligation.