

Project _____

Item Number _____

Quantity _____

Square Dome Oven



*image shown has aftermarket brick work

Stone Hearth Pizza Dome Oven

Models:

- DOME39S:** Square dome pizza oven
- DOME47S:** Square dome pizza oven
- DOME55S:** Square dome pizza oven

Univex Pizza Oven

Features:

- Hand cut and laid refractory brick
- Round internal cooking chamber
- Very well insulated, exterior can be touched while oven is at full temperature
- Simple to use controls and very low maintenance
- Long life span with low coast of ownership

Included Accessories:

- Iron stand
- Iron door
- Thermometer
- Stack exhaust internal diameter 20cm(7.87in)

Univex Corporation

Options:

- Black or Silver painted body

Warranty:

- One year, on-site parts and labor

Warranty Details

The oven carries a one year, on-site parts and labor warranty against any flaws in materials and workmanship. This period begins on the date of the purchase and, provided the unit is used in accordance with our instructions, is in full effect for one year from that date. Any work performed under this warranty must be performed between the hours of 8am and 5pm Monday through Friday. Univex will not pay for overtime charges for work performed other than during normal business hours. Damage incurred in transit or from installation error, accident, alteration or misuse is not covered. Univex shall not be liable for any consequential compensatory, incidental, or special damages. Contact the Univex service department for any warranty claims.

Stone Hearth Pizza Dome Oven

Gas

Dimensions

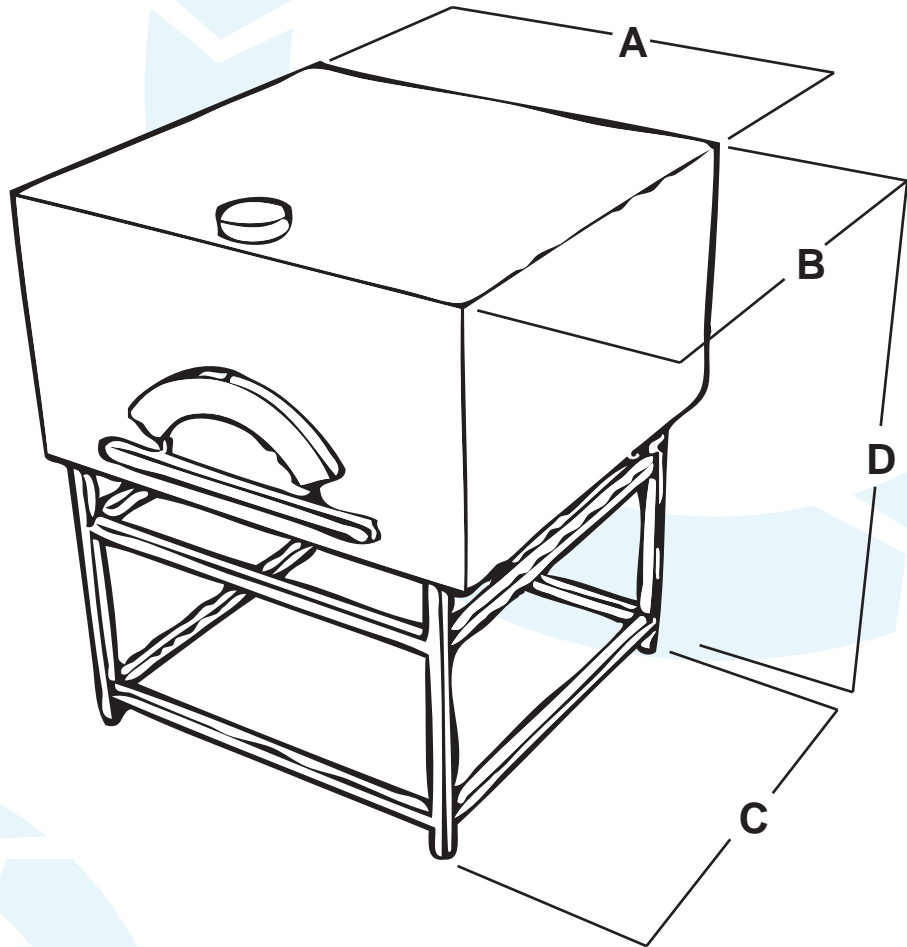

Model	Internal Diameter	A width	B Oven depth	C Overall depth	D height	Weight	# of pizzas
DOME39S	39.37" 100cm	55.11" 140cm	55.11" 140cm	57.08" 145cm	78.74" 200cm	2,866Lbs 1300kg	6
DOME47S	47.25" 120CM	62.99" 160cm	62.99" 160cm	64.96" 165cm	78.74" 200cm	5,070Lbs 2300kg	8
DOME55S	55" 140cm	70.86" 180cm	70.86" 180cm	72.83" 185cm	78.74" 200cm	5,511Lbs 2500kg	11